

**MODEL 5100-02-IT**

***IT Series***

**COMBUSTIBLE GAS SENSOR MODULE**

**Version 3.00A**



**APPROVED**

**APPLICABILITY & EFFECTIVITY**

**Effective for all Model 5100-02-IT Modules manufactured after December 1, 2011.**

**Instruction Manual Part Number T12019  
Rev. E**

**FM APPROVAL**

ONLY THE FOLLOWING ITEMS, FUNCTIONS AND OPTIONS ARE FM\* APPROVED

**Model 5100-02-IT Combustible Gas Sensor Module****Sensor Module**

Model 5100-02-IT-AL	Combustible Gas Sensor Module
Model 5100-02-IT-SS	Combustible Gas Sensor Module, 316SS

**Calibration Equipment**

Model 1200-26	Calibration Gas Delivery System
Model 1290-02	Combustible Gas Cylinder
Model 5358-01	Calibration Head, Standard
Model 5360-00	Calibration Gas Delivery Fitting
Model 1260-02	Combustible 50% LEL Gas Cylinder
Model 1260-42	Cylinder H2 50% LEL Type A
Model 1250-01	Gas Sensor Calibrator Kit, Type A
Model 1256-01	Regulator Type A Calibrator
Model 5394-51	Remote Sensor Option – 5100-02-IT

**Notes:**

- 1) FM Approval applies only to conventional (one cable run per sensor module) or multiplexed (multiple sensor modules per cable) installations. Apparatus must be installed in accordance with National Electrical Code.
- 2) FM Comments

\*FM Approvals, a subsidiary of FM Global

- ◆ Project# 3021050
-

**TABLE OF CONTENTS**

<b>1. PRODUCT DESCRIPTION</b> .....	<b>3</b>
1.1 GENERAL.....	3
1.2 PRODUCT CONFIGURATION.....	3
1.3 THEORY OF OPERATION.....	3
1.4 MODES OF OPERATION.....	3
1.5 MECHANICAL.....	4
1.6 INTERCONNECT WIRING.....	5
1.7 POWER REQUIREMENTS.....	5
<b>2. CAUTIONS &amp; WARNINGS</b> .....	<b>7</b>
2.1 INTRODUCTION.....	7
2.2 IT MODULES - GENERAL.....	7
2.3 WIRING.....	7
<b>3. QUICK START</b> .....	<b>9</b>
3.1 OVERVIEW.....	9
3.2 WIRING.....	9
3.3 MODULE INSTALLATION.....	9
3.4 TRANSMITTER INSTALLATION.....	9
3.5 START-UP & OPERATION.....	9
<b>4. INSTALLATION</b> .....	<b>10</b>
4.1 SENSOR MODULE LOCATIONS.....	10
4.2 WIRING (FIGURE 4-2 REFERS TO ANALOG, MODBUS AND SENTRY OPERATION).....	10
4.3 ENCLOSURE INSTALLATION.....	11
4.4 TRANSMITTER AND SENSOR INSTALLATION.....	12
4.5 MODULE ADDRESS SWITCH.....	13
<b>5. OPERATION</b> .....	<b>18</b>
5.1 DATA ENTRY KEY PAD.....	18
5.2 MAIN MENU.....	19
5.3 SET-UP.....	20
5.4 MAINTENANCE FUNCTIONS.....	23
<b>6. CALIBRATION</b> .....	<b>24</b>
6.1 CALIBRATION FREQUENCY.....	24
6.2 CALIBRATION PREPARATION.....	24
6.3 CALIBRATION GAS DELIVERY METHODS.....	24
6.4 CALIBRATION PROCEDURE.....	24
6.5 SENSOR EXPOSURE TO GAS.....	24
6.6 CALIBRATION SUB-MENU.....	25
<b>7. SERVICE</b> .....	<b>26</b>
7.1 MODULE SUB ASSEMBLY.....	26
7.2 ENCLOSURE REPLACEMENT.....	26
7.3 TRANSMITTER REPLACEMENT.....	27
7.4 SENSOR REPLACEMENT.....	27
7.5 INSTALLATION INSPECTION.....	27

<b>8. APPENDICES .....</b>	<b>29</b>
8.1 APPENDIX A: SPECIFICATIONS.....	29
8.2 APPENDIX B: MODEL NUMBERS, PARTS LIST & PARAMETERS.....	30
8.3 APPENDIX C: LIMITED WARRANTY.....	31
8.4 APPENDIX D: REMOTE SENSOR OPTION .....	32
8.5 APPENDIX E: HART.....	34
8.6 APPENDIX F: MODBUS MEMORY MAP .....	42
8.7 APPENDIX G: COMBUSTIBLE GAS SCALING FACTORS.....	43
8.8 APPENDIX H: FM APPROVAL .....	44
8.9 APPENDIX I: SIL-2 APPROVAL CERTIFICATE.....	46

### LIST OF FIGURES

FIGURE 1 - 1: MODEL 5100-02-IT COMBUSTIBLE SENSOR – MOUNTING OPTIONS.....	5
FIGURE 1 - 2: MODEL 5100-02-IT-S1 (AND S2) COMBUSTIBLE SENSOR – 316SS DIMENSIONS.....	6
FIGURE 1 - 3: MODEL 5100-02-IT-A1 (AND A2) COMBUSTIBLE SENSOR –ALUMINUM DIMENSIONS .....	6
FIGURE 4 - 1: TYPICAL MOUNTING OPTIONS.....	10
FIGURE 4 - 2: TRANSMITTER FACE PLATE.....	14
FIGURE 4 - 3: 4-20 MA CIRCUITS TYPES 5100-02-IT .....	14
FIGURE 4 - 4: 4-20 MA CIRCUITS TYPES 5100-02-IT – CONNECTIONS.....	15
FIGURE 4 - 6: REMOTE ALARM RESET .....	16
FIGURE 4 - 5: DIGITAL INTERFACE CONNECTIONS .....	16
FIGURE 4 - 7: TERMINATION DRAWING .....	17
FIGURE 5 - 1: FACE PLATE WITH DATA ENTRY KEY PAD.....	18
FIGURE 6 - 1: MODEL 5358-01 CALIBRATION ADAPTER .....	24
FIGURE 7 - 1: MODULE COMPONENTS .....	26
FIGURE 8 - 1: REMOTE SENSOR OPTION .....	32
FIGURE 8 - 2: HART .....	34
FIGURE 8 - 3: 4-20 MA CIRCUITS TYPES 5100-02-IT – CONNECTIONS - HART .....	35

### LIST OF TABLES

TABLE 4 - 1: MINIMUM WIRE GAUGES.....	12
TABLE 4 - 2: SENSOR MODULE EXTERNAL INTERFACES .....	13
TABLE 4 - 3: SENSOR MODULE ADDRESS SWITCH POSITIONS.....	13
TABLE 5 - 1: MASTER MENU .....	19
TABLE 5 - 2: OPERATION DISPLAY VALUES .....	19
TABLE 5 - 3: SET-UP CONFIGURATION .....	21
TABLE 5 - 4: MAINTENANCE MENU .....	23
TABLE 6 - 1: CALIBRATION.....	25
TABLE 8 - 1: MODBUS MEMORY MAP .....	42

## 1. PRODUCT DESCRIPTION

### 1.1 GENERAL

The Model 5100-02-IT Catalytic Bead Combustible Gas Sensor Module is a member of the **Sentry Information Technology "IT"** family of gas sensor transmitter modules. **IT** modules offer a broad array of features including:

- Integral Alphanumeric display
- 180 day calibration frequency
- SIL-2 Certified
- FM Approved for performance and hazardous locations
- 4-20 mA output
- Modbus<sup>®</sup> RTU interface
- SMC Sentry interface
- 316 Stainless steel enclosure option
- Remote alarm reset
- Optional Alarm Relays
- Remote sensor option



**IT** modules are designed, and approved for installation and operation in hazardous locations.

### 1.2 PRODUCT CONFIGURATION

Various module configuration options are available. Where applicable, these options are factory configured prior to shipment.

### 1.3 THEORY OF OPERATION

Catalytic bead gas sensors detect gas by comparing the resistance of two heated elements. One element is catalytic to enhance the burning of combustible gases, the other element is passive. Electronic circuits are used to compare the change in the catalytic bead resistance relative to the passive bead. The relative change is calibrated to determine the concentration of the gas of interest.

### 1.4 MODES OF OPERATION

#### 1.4.1 SENTRY INTERFACE

All **IT** gas sensor modules can be installed on Sierra Monitor Sentry Model 5000 controllers. Catalytic bead modules communicate as a combustible gas sensor module (Type 2 communication) and are automatically detected by the Sentry controller. When it is installed in a Sentry system the **IT** module must have a unique address which can be established by setting an address between 1 and 8 on the rotary switch accessible from the cover plate as illustrated in Figure 4-1. Figure 4-4 in this manual provides the wiring terminations for connections to the Sentry controller.

When the module is operated in conjunction with a Sentry controller, the alarm relay setup (See section 4.3) should be set to "Sentry", allowing the Sentry controller to manage alarm relay action rather than the 5100-02-IT Gas Sensor Module.

An available option, applicable only to Sentry installations, is a connector card which allows daisy chain installation using the Sentry multiplex capability. Use of the connector card reduces costs by avoiding the requirement for wiring junction boxes. The connector card has two sets of connections, allowing for a continuous run to the next module

<sup>®</sup> Registered trademark of Schneider Electric.

**1.4.2 MODBUS OPERATION**

An RS-485 Modbus RTU serial interface allows direct connection to standard PLCs and DCSs. The Module Address Switch (section 4.5) allows the user to select up to 15 different Modbus addresses. Also, up to 254 different Modbus Addresses are available via menu selection. Figure 4-5 in this manual provides the wiring terminations for Modbus connections.

**1.4.3 ANALOG OPERATION**

The analog 4-20 mA interface allows direct connection to standard controller and distributed system. The module is an active current source.

The standard configuration is set up for a 3-wire non-isolated connection. An optional 4-wire isolated connection is also available and can be enabled by changing JP1 and JP2.

**1.4.4 REMOTE SENSOR (APPENDIX E)**

The Remote Sensor option enables the remote mounting of the sensor up to 50' from the transmitter.

**1.4.5 HART CONNECTION (APPENDIX F)**

A HART interface option is available. Refer to Appendix F for information.

**1.4.6 OPTIONAL INTEGRAL RELAYS**

The optional relays are integral to the gas sensor module and are rated as SPDT, 250VAC, 5 Amps for the High Alarm and Low Alarm relays and SPDT, 250VAC, 0.25 Amp for the Trouble relay.

\* HART option, alarm relays are all SPDT, 250VAC, 2 Amp

If the gas sensor module is provided with the optional relays, it will include Terminal P4 on the interface board (Figure 4-3). Relay output connections are on P4.

**1.4.7 REMOTE ALARM RESET**

An input is available for connection of remote alarm reset/acknowledge. Figure 4-6 provides the wiring termination for connecting the remote alarm reset. This only resets local alarms, not Sentry alarms.

**1.5 MECHANICAL**

The sensor module of comprised of the following three primary components:

**◆ ENCLOSURE**

Standard on the 5100-02-IT is an explosion-proof, rain-tight cast aluminum electrical housing (Figure 1-2) with three ¾" FNPT conduit hubs. The 5100-02-IT-SS has a 316 Stainless Steel enclosure (Figure 1-3). Both enclosure covers have a viewing window. The design of the enclosure allows 3-way mounting choices as shown in figure 1-1.

**◆ TRANSMITTER ELECTRONICS**

Electronic Assembly consisting of one printed circuit board assembly mounted under a cover plate, plugged into one field termination board. Connectors for wiring for power, signal interface and alarm relays are located on the bottom of the termination board.

**◆ SENSOR ASSEMBLY**

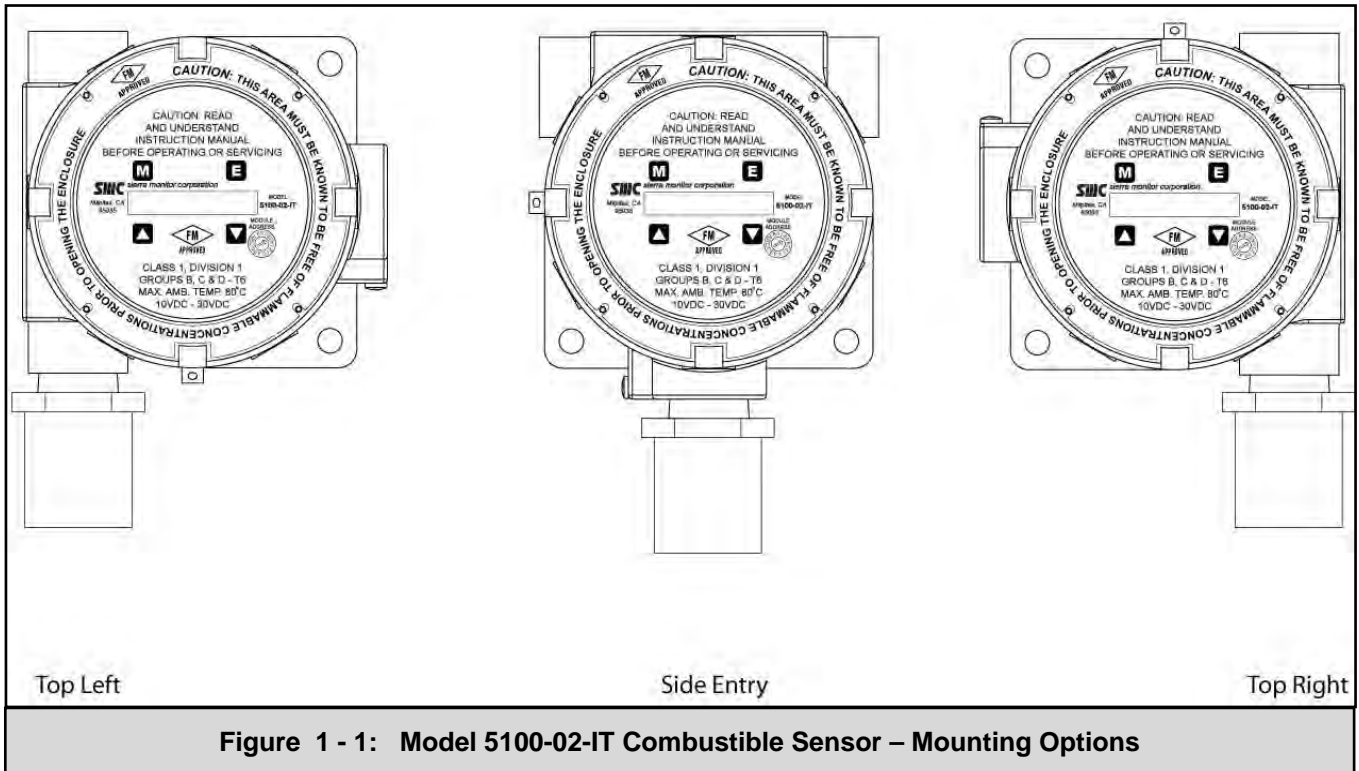
The sensor assembly includes an explosion proof housing containing the gas sensor and a wiring harness for connection to the transmitter. The sensor assembly threads into one hub of the enclosure. The exposed end of the sensor assembly is threaded to allow connection of a rain-shield or calibration gas.

**1.6 INTERCONNECT WIRING**

Not supplied with the sensor module, but necessary to the installation and operation is the multi conductor wiring which connects the module to its power source and controller. Before this wiring is installed it is important to read and understand the control system installation instructions to determine wiring alternatives requirements and alternatives.

**1.7 POWER REQUIREMENTS**

**IT** modules operate on DC power between 10 VDC and 30 VDC. Regulated DC power must be supplied from a separate source, or from an approved Sentry or **IT** controller.



**Figure 1 - 1: Model 5100-02-IT Combustible Sensor – Mounting Options**

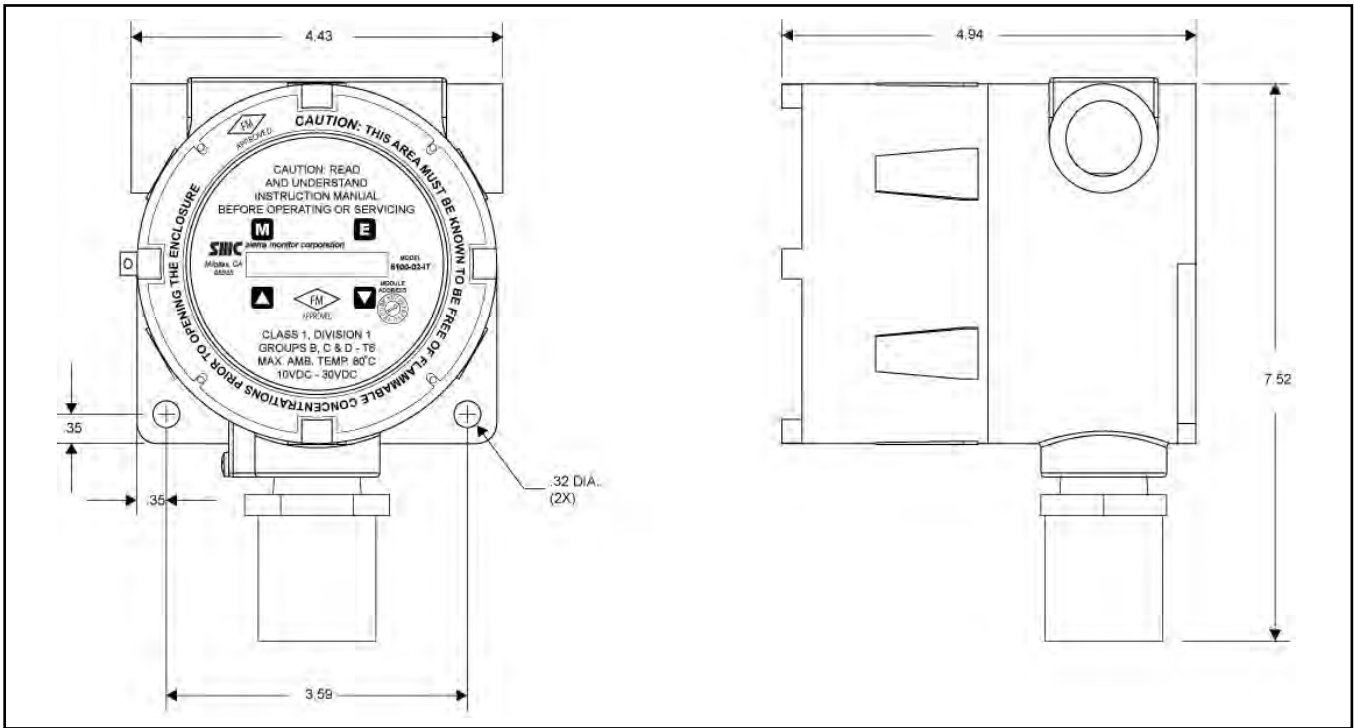


Figure 1 - 2: Model 5100-02-IT-S1 (and S2) Combustible Sensor – 316SS Enclosures, Dimensions

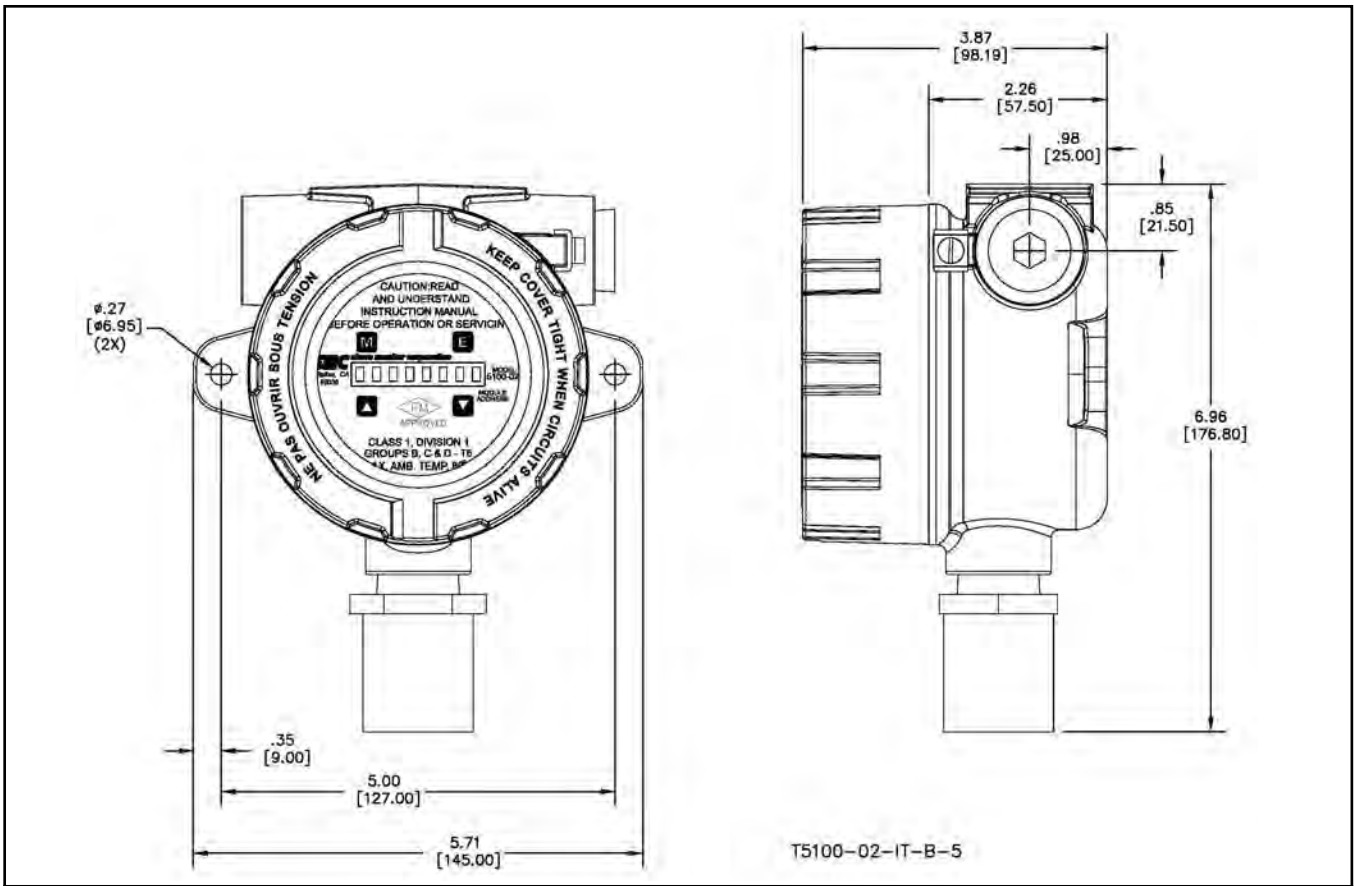


Figure 1 - 3: Model 5100-02-IT-A1 (and A2) Combustible Sensor – Cast Aluminum Enclosures, Dimensions



## 2. CAUTIONS & WARNINGS

### 2.1 INTRODUCTION

Although *IT* Transmitter Modules are designed and constructed for installation and operation in industrial applications including "hostile" environments, caution should be taken to insure that the installation is made in compliance with this instruction manual and that certain procedures and conditions are avoided. This chapter discusses the necessary cautions. **Read the entire chapter prior to installation of the equipment.**

### 2.2 IT MODULES - GENERAL

Avoid installing sensor modules where they will be unnecessarily exposed to wind, dust, water (esp. direct hose down), shock, or vibration. Observe temperature range limitations.

Sensors may be adversely affected by prolonged exposure to certain materials. Loss of sensitivity, or corrosion, may be gradual if such materials are present in low concentrations. These materials include: silicones, sulfides, Halides (compounds containing chlorine, fluorine, bromine, iodine), acid vapors, caustic liquids or mists.

Care has been taken by the manufacturer to ship your modules in protective packaging to avoid contamination prior to installation. It is recommended that the modules remain protected during installation and that the covering be removed immediately prior to system start-up.

During normal use the sensor is protected from dirt and oil contamination by a sintered metal cover. If this cover becomes clogged, the response of the sensor will be reduced. Protect the sensor from contamination by careful placement, or by use of rain and dust shields.

Sensor modules must not be painted. Paint may contain compounds which will contaminate the sensor. Paint will cause clogging of the sintered metal cover and will cause difficulties during attachment of the calibration head or other maintenance activity. It is recommended that the module be tagged "DO NOT PAINT".

### 2.3 WIRING

The manufacturer recommends that extra caution be taken where the installation is near any sources of electromagnetic or radio frequency interference. Precautions include:

- Avoid running sensor module cable close to high power cables, radio transmission lines, or cables subject to pulses of high current.
- Avoid running cables near large electric motors or generators.
- When shielding is used, it is recommended that shields be grounded at the controller and nowhere else.
- All splices must be via either a termination hardware system or soldered. Improperly spliced cable can result in corrosion, resistance changes and system errors. The use of wire nuts and crimp-on connectors is unacceptable.

**NOTE**

*Installation and wiring must be in accordance with the National Electrical Code. AC Voltage conductors are not to be run in the same conduit as DC voltage conductors.*

#### 2.3.1 CATALYTIC BEAD SENSOR MODULES

Model 5100-02-IT Gas Sensor Modules are FM performance approved for detection of Combustible gas (methane and hydrogen). The sensor is cross sensitive to the combustible gases indicated in Table 2-1. Risk management planning should take into consideration the potential for the presence of other gases in the monitored area.

Note that the 5100-02-IT has a gas factor scaling feature in which a calibration standard of Methane or Propane may be used in conjunction with scaling factors to cause alarm function in %LEL scale of another gas. See Appendix G.

Acetaldehyde	2,3-Dimethylpentane	Methyl Chloride
Acetic Acid	2,3-Dimethylpropane	Methylcyclohexane
Acetic Anhydride	Dimethylsulphide	Methylenedichloride
Acetone	1,4-Dioxane	Methylethylether
Acetylene	Epichlorohydrin	Methylethylketone
Alkyl Alcohol	Ethane	Methyl Formate
Ammonia	Ethyl Acetate	Methylmercaptan
n-Amyl Alcohol	Ethyl Alcohol	Methylpropionate
Aniline	Ethylamine	Methyl n-propylketone
Benzene	Ethyl Benzene	Napthalene
Biphenyl	Ethyl Bromide	Nitromethane
1,3-Butadiene	Ethyl Chloride	n-Nonane
n-Butane	Ethylcyclopentane	n-Octane
iso-Butane	Ethylene	n-Pentane
Butene-1	Ethylenedichloride	i-Pentane
cis-Butene-2	Ethyleneoxide	Propane
trans-Butene-2	Diethyl Ether	n-Propyl Alcohol
n-Butyl Alcohol	Dimethoxyethane	n-Propylamine
iso-Butyl Alcohol	Dimethyl Ether	n-Propylchloride
tert-Butyl-Alcohol	Dimethylformamide	Propylene
n-Butyl Benzene	Ethyl Formate	Propyleneoxide
iso-Butyl Benzene	Ethylmercaptan	iso-Propylether
n-Butyric Acid	n-Heptane	Propyne
Carbon Disulfide	n-Hexane	Toluene
Carbon Monoxide	Hydrazine	Triethylamine
Carbon Oxysulphide	Hydrogencyanide	Trimethylamine
Chlorobenzene	Hydrogen	Vinylethylether
Cyanogen	Hydrogen Sulfide	o-Xylene
Cyclohexane	Methane	m-Xylene
Cyclopropane	Methyl Actetate	p-Xylene
n-Decane	Methyl Alcohol	JP-4 (Jet Fuel)
Diethylamine	Methylamine	
Dimethylamine	Methyl Bromide	

**Table 2 - 1: Combustible gases detected by Model 5100-02-IT Combustible Gas Sensor Module**

## 3. QUICK START

### 3.1 OVERVIEW

The gas sensor module has been supplied factory calibrated and ready for immediate installation and operation. An installer familiar with installation and operation of gas detection products can use this section to begin immediate use of the module.

### 3.2 WIRING

See section 4.2 to determine if 3-wire or 4-wire operation is necessary.

Provide twisted shielded wiring from the power supply/control device to the sensor module location. Use stranded wire that is 18 AWG or larger.

### 3.3 MODULE INSTALLATION

The sensor module can be mounted in a variety of configurations supported by the conduit. See figure 1-1 to determine which configuration is best for your specific application. The default configuration enables the modules to be put in line with other modules with the sensor element below the transmitter. To change the configuration simply remove the transmitter and rotate to the appropriate configuration and remount the standoffs and transmitter.

The module is designed to be installed on a ¾" conduit. Two important warnings:

- **The installation must meet any hazardous environment codes for electrical equipment.**
- **The sensor module enclosure mounting must be spaced far enough from any vertical surface to allow removal and replacement of the sensor assembly which is threaded into one ¾" conduit entry.**
- **Sensor housing must be oriented vertically pointing downward.**
- **If module is installed outdoors it is recommended that it be sheltered from direct sunlight.**

### 3.4 TRANSMITTER INSTALLATION

To install the transmitter printed circuit assembly into the housing, carefully turn the faceplate so that the printing is in the correct horizontal position for the mounting configuration and slide the assembly over the two stand-offs in the enclosure.

Hand tighten the two captive panel thumb screws into the stand-offs. Replace the enclosure cover prior to providing power to the transmitter

- **If the transmitter is installed in a classified hazardous area, replace the threaded cover prior to providing power.**

### 3.5 START-UP & OPERATION

To begin operation of the sensor module activate the instrument loop with 10-30 VDC. Each time the sensor module is powered up it will perform a warm-up for approximately 5-10 minutes. During this time the display will read "Starting". The loop output will be held at 4 mA.

**NOTE:** If the sensor is uncalibrated, the startup display will state "START" instead of "STARTING"

After the warm-up period has expired, the display will indicate the gas concentration. Also, the instrument loop will be released to output current in the range of 4 to 20 mA. The actual current is linear with the gas concentration.

## 4. INSTALLATION

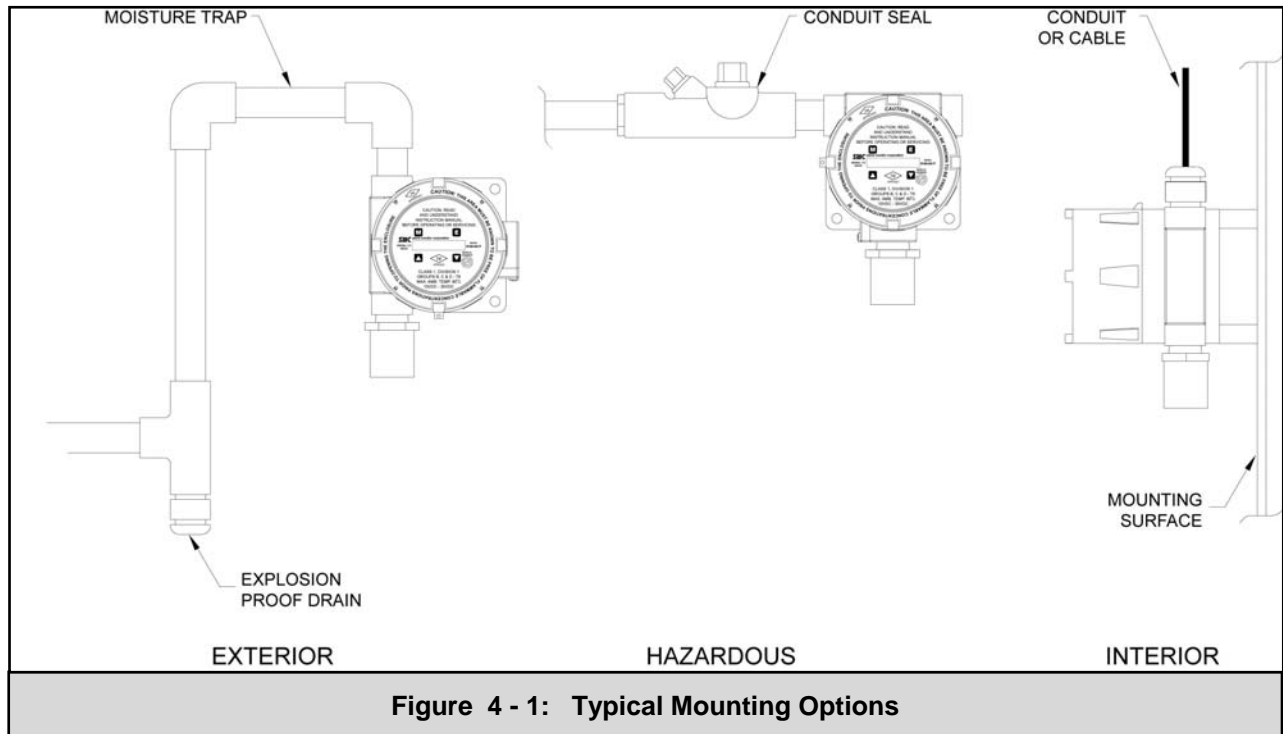
**NOTE**

*All IT modules are factory pre-configured and calibrated.  
All modules are tagged to indicate the configuration including the sensor module number  
Identify all components during unpacking and install using the factory configuration.*

### 4.1 SENSOR MODULE LOCATIONS

Select locations for each sensor modules based on the following:

- Modules should be placed close to the potential source of gas.
- Modules should be placed in areas accessible for calibration.
- Sensors should be pointed down and the conduit should include an inverse trap to reduce moisture (condensation) from accumulating in the electronics enclosure.
- Remote calibration fitting (5360-00) should be used to facilitate calibration gas delivery. Run polyurethane tubing (1/4" O.D. x 1/8" I.D.) from fitting to an accessible location.



**NOTE**

*Module must always be installed vertically with sensor pointing down.*

### 4.2 WIRING (Figure 4-2 refers to Analog, Modbus and Sentry operation)

#### 4.2.1 ANALOG 4-20 MA OPERATION

For a 3-Wire non-isolated connection, set jumpers, located on the bottom of the transmitter board, to the lower position as illustrated in Figure 4.4. Verify that both jumpers are in the position marked by 3-wire. When using a 3-wire connection, a minimum of an 18 AWG, 3 conductor shielded cable must be used. A

cable shield must never be used as a conductor. Larger gauge wire is recommended with distances over 1000'. Connect wires as shown in figure 4-4.

For a 4-Wire isolated connection, set jumpers, located on the bottom of the transmitter board, to the upper position as illustrated in Figure 4.4. Verify that both jumpers are in the position marked by 4-wire. When using a 4-wire connection, a minimum of 2 each of an 18 AWG, 2 conductor twisted/shielded pair cable must be used. A cable shield must never be used as a conductor. Larger gauge wire is recommended with distances over 1000'. Connect wires as shown in figure 4-4.

#### **4.2.2 MODBUS OPERATION USING RS-485 CONNECTION**

Use a minimum of 18 AWG, 2 conductor for DC power connection. No shield required. In addition use a minimum of 24 AWG, low capacitance, shielded data cable for RS485 half duplex communication. The installation may be planned in a manner which provides up to 32 sensor modules on a single home run.

##### **TERMINATION RESISTOR JUMPERS:**

Termination resistors are used in RS-485 wire runs to provide impedance matching. The IT series modules use a 120 Ohm resistor for this function. The cable being used for this RS-485 connection must have a minimum of 100 Ohm impedance with a maximum of 120 Ohms.

Installations where the cable length is under 100', termination resistors may not be required. In installations where the cable length is greater than 100', it is recommended to place the termination jumpers on the first device and last device on the RS-485 wire run. Termination jumpers must be removed from all other modules connected between the first and last device. The first device in the RS-485 multiplexed bus is usually a gas controller or PLC. Factory term resistor setting is "not enabled."

##### **BIAS JUMPERS: (BIAS A, BIAS B)**

Bias resistors are used to force RS-485 receiver outputs to a known (fail-safe) state, when the bus is idle. Bias jumpers are always installed in pairs as the bias must be placed on both the TX A and TX B lines. Sierra Monitor's IT series of combustible gas sensors automatically apply the bias jumpers, and are factory installed so that the bias is always enabled.

#### **4.2.3 SENTRY OPERATION USING SENTRY PSG CONNECTION**

Use a minimum of 18 AWG, 3-conductor cable up to 2000'. The cable may or may not be shielded. We recommend shielded cable in circumstances that there could be RF or EM interference present. Shield to be terminated and grounded only at the Sentry controller. Shield must be cut and dressed at the module end so that no part of it comes in contact with the conduit or ground.

##### **NOTE:**

*Be sure to follow all local electric code and safety requirements when installing the 5100-02-IT Gas Sensor Module*

#### **4.2.4 GENERAL**

Install conduit as required by local code or construction specifications. Provide for splice boxes where multiple modules will be wired to a single run. Pull conductors of the correct gauge wire from the controller to each splice box and from the respective splice box to each planned module location. See for proper wire termination in the splice box. Twisted wire secured with wire nuts is not an acceptable splice.

##### **NOTES**

*RFI Noise Suppressor must be added to power/ground as per Appendix D.*

*The drain wire of shielded cable must NOT be used as one of the conductors.*

*Installation and wiring must be in accordance with the National Electrical Code. Temperature rating of cable wire must be at least 75°C. If cable runs through higher temperature environments, it must be specified for that environment.*

#### **4.3 ENCLOSURE INSTALLATION**

To protect the transmitter and sensor assembly they should be removed from the enclosure and preserved until final installation and wiring termination.

Number of modules	Maximum length of wire run (feet)				
	500	1,000	2,000	3,000	5,000
1	18	18	16	16	14
2	18	18	14	12	xx
3	18	16	12	xx	xx
4	16	14	12	xx	xx

**Table 4 - 1: Minimum Wire Gauges**

Prior to installation and wiring.

1. Remove the transmitter from the module housing by:
  - Unscrew the two captive panel screws in the face plate.
  - Lift the transmitter out of the enclosure housing.
  - Unplug the sensor cable from transmitter assembly connector J1.
  - Remove the sensor assembly from the enclosure hub.
2. Install the module housing onto the end of the supply conduit and/or bolt into position as required.

**NOTES**

*When housing earth grounding is required for the installation a grounding lug is located in the base of the enclosure. Install the earth ground wire under the green lug.*

#### 4.4 TRANSMITTER AND SENSOR INSTALLATION

When all pre-wire is complete:

1. Install sensor assembly in the open hub on the module enclosure. The sensor assembly thread must be fully seated into the hub and tightened to maintain explosion proof assembly.
2. Connect the sensor assembly cable to top transmitter board connector J1.
3. Align the headers between the top transmitter board and the lower termination board and push together.
4. Turn rotary switch to correct sensor address if required.
5. Carefully return the transmitter to the enclosure installing it over the two stand-off's. Tighten the retaining screws into the stand-offs.
6. Cycle power to accept module address change.

P1	PCB Label	Function	
1	Switch	IN +	Digital Input SW +
2		IN -	Digital Input SW -
3	4-20	IN +	4-20 mA Input +
4		IN -	4-20 mA Input -
5	GND	Ground	
6	4-20	OUT +	4-20 mA Output
7		OUT -	4-20 mA Output

P2	PCB Label	Function	
1	RS 485	+	RS 485 (+) (A)
2		-	RS 485 (-) (B)
3		S	RS 485 shield (Isolated GND)
4	RS 485	+	RS 485 (+) (A)
5		-	RS 485 (-) (B)
6		S	RS 485 shield (Isolated GND)

P3B	PCB Label	Function
1	P	VDC Power
2	S	Sentry Signal or Communication
3	G	VDC Ground
<b>P3A</b>		
4	P	VDC Power
5	S	Sentry Signal or Communication
6	G	VDC Ground

**P4 Connections are only available when the optional Relays are included**

P4	PCB Label		Function
1	WARN	N/C	Low Alarm Relay NC
2		COM	Low Alarm Relay COM
3		N/O	Low Alarm Relay NO
4	ALARM	N/C	High Alarm Relay NC
5		COM	High Alarm Relay COM
6		N/O	High Alarm Relay NO
7	TRBL	N/C	Trouble Alarm Relay NC *
8		COM	Trouble Alarm Relay COM*
9		N/O	Trouble Alarm Relay NO*
* Trouble relay is fail safe so it is energized for normal operation, functions are labeled for normal operation.			
<b>Table 4 - 2: Sensor Module External Interfaces</b>			

- Establish the module address according to section 4.5.

**NOTES**  
*The starting delay period normally takes approximately 3 minutes but under some circumstances can take longer.*

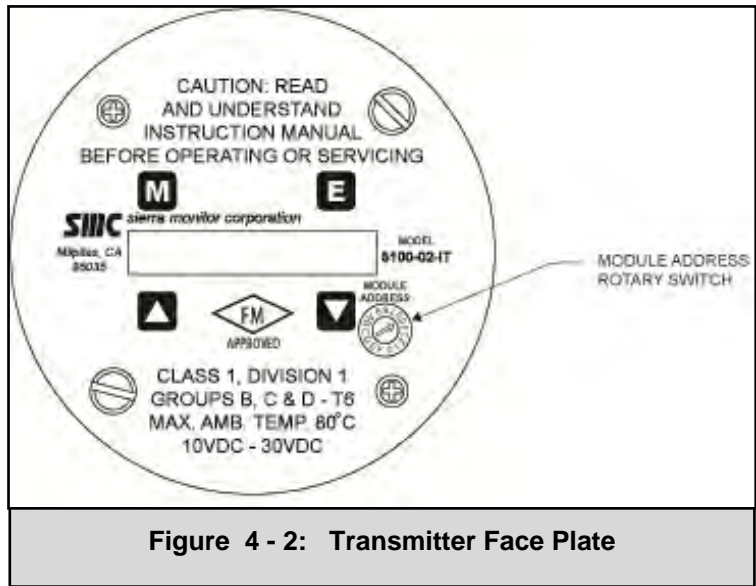
**4.5 MODULE ADDRESS SWITCH**

For digital interface applications the module address switch (or Modbus node) must be set per Table 4-2:

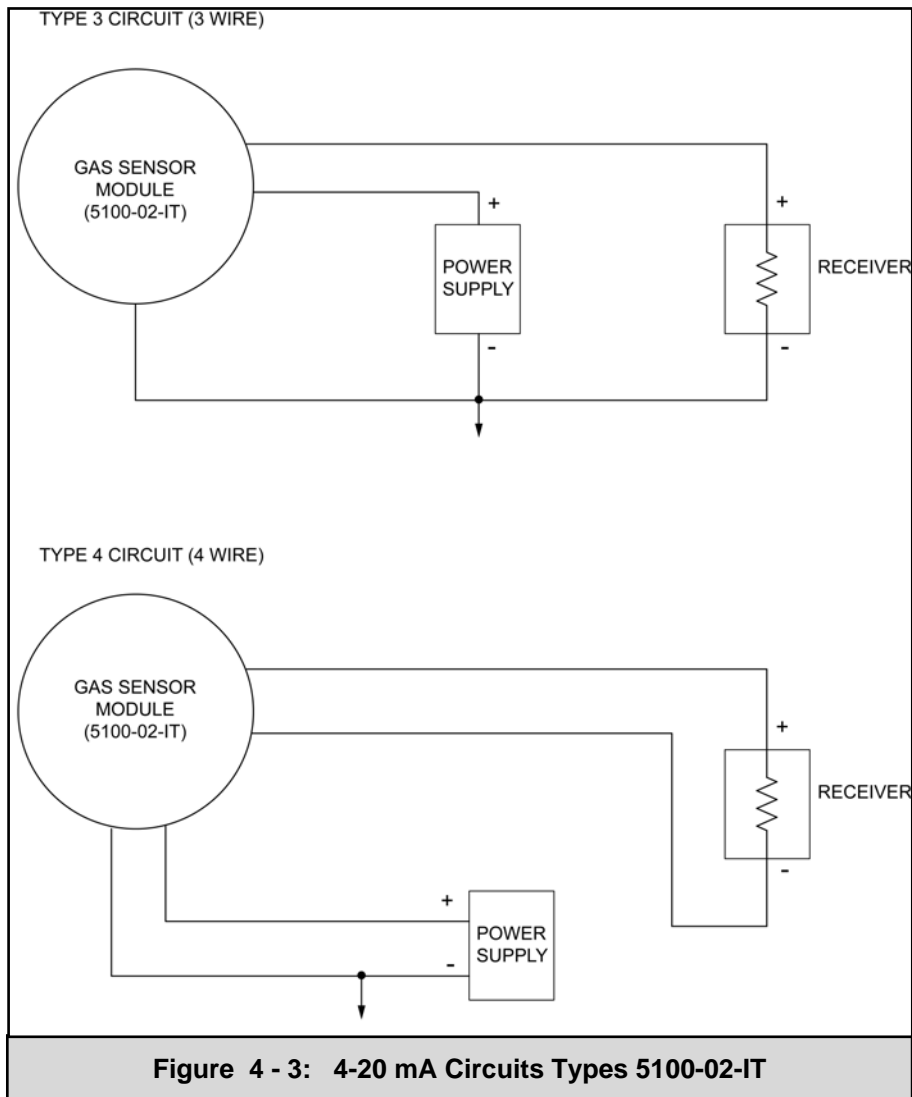
POSITION	ADDRESS	POSITION	ADDRESS
1	Sensor 1	9	Sensor 09
2	Sensor 2	A	Sensor 10
3	Sensor 3	B	Sensor 11
4	Sensor 4	C	Sensor 12
5	Sensor 5	D	Sensor 13
6	Sensor 6	E	Sensor 14
7	Sensor 7	F	Sensor 15
8	Sensor 8	0	Software Menu

**NOTE**  
*For Sentry applications only sensor addresses 1-8 are allowed. If using Modbus output sensor addresses 1-15 are available. Position 0 allows the Modbus Address to be set by software menu, in the range 16-254.*

**Table 4 - 3: Sensor Module Address Switch Positions**

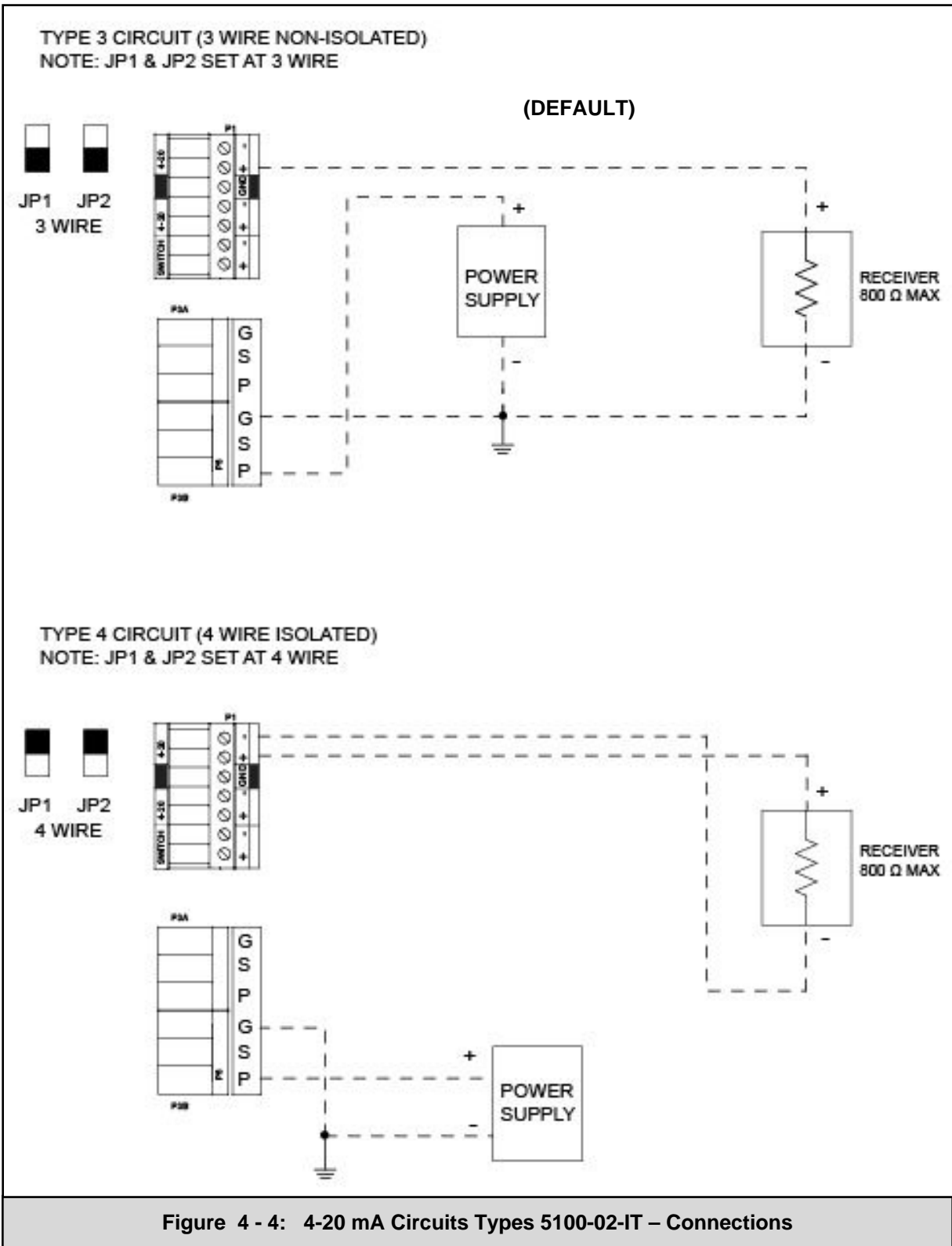


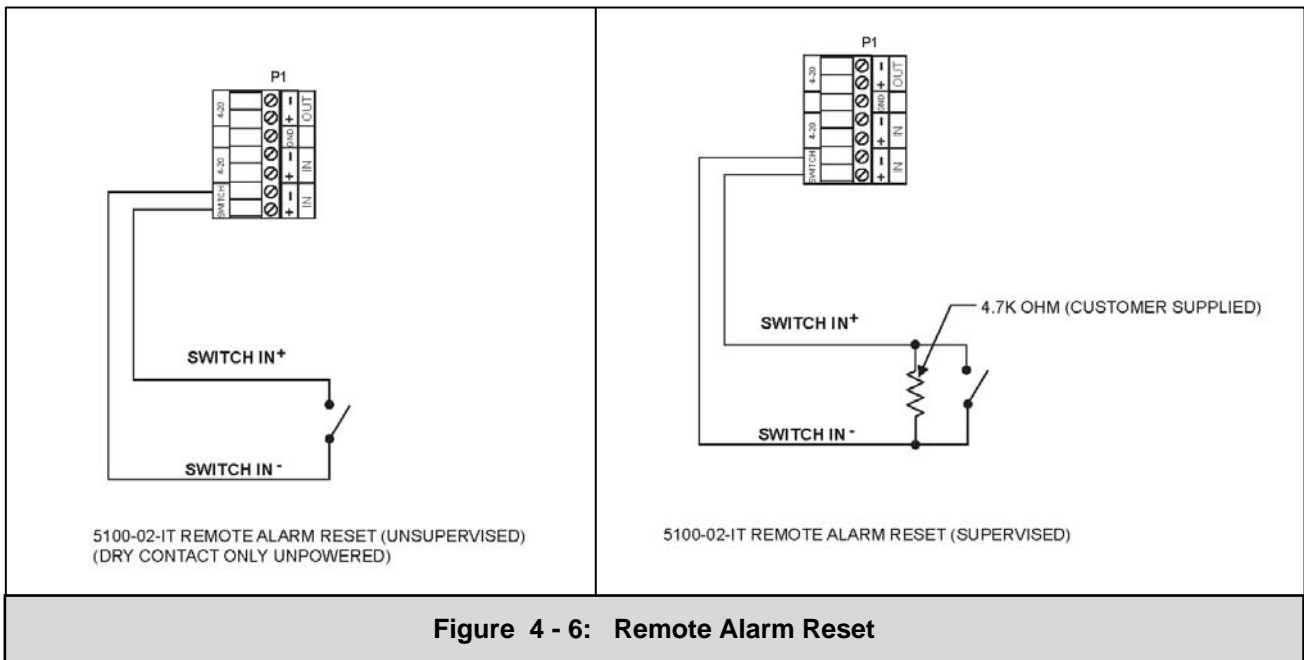
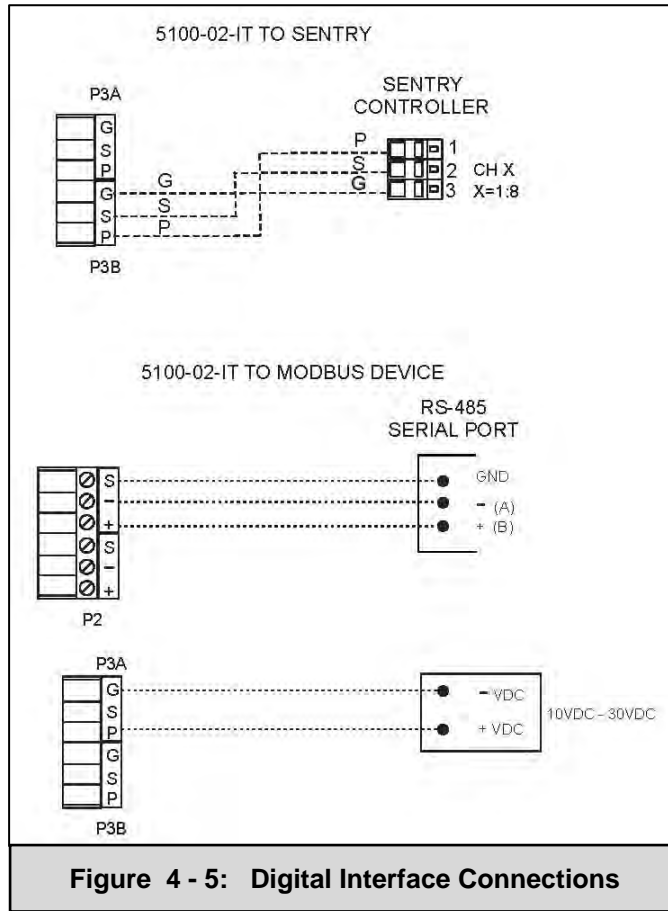
**Figure 4 - 2: Transmitter Face Plate**



**Figure 4 - 3: 4-20 mA Circuits Types 5100-02-IT**







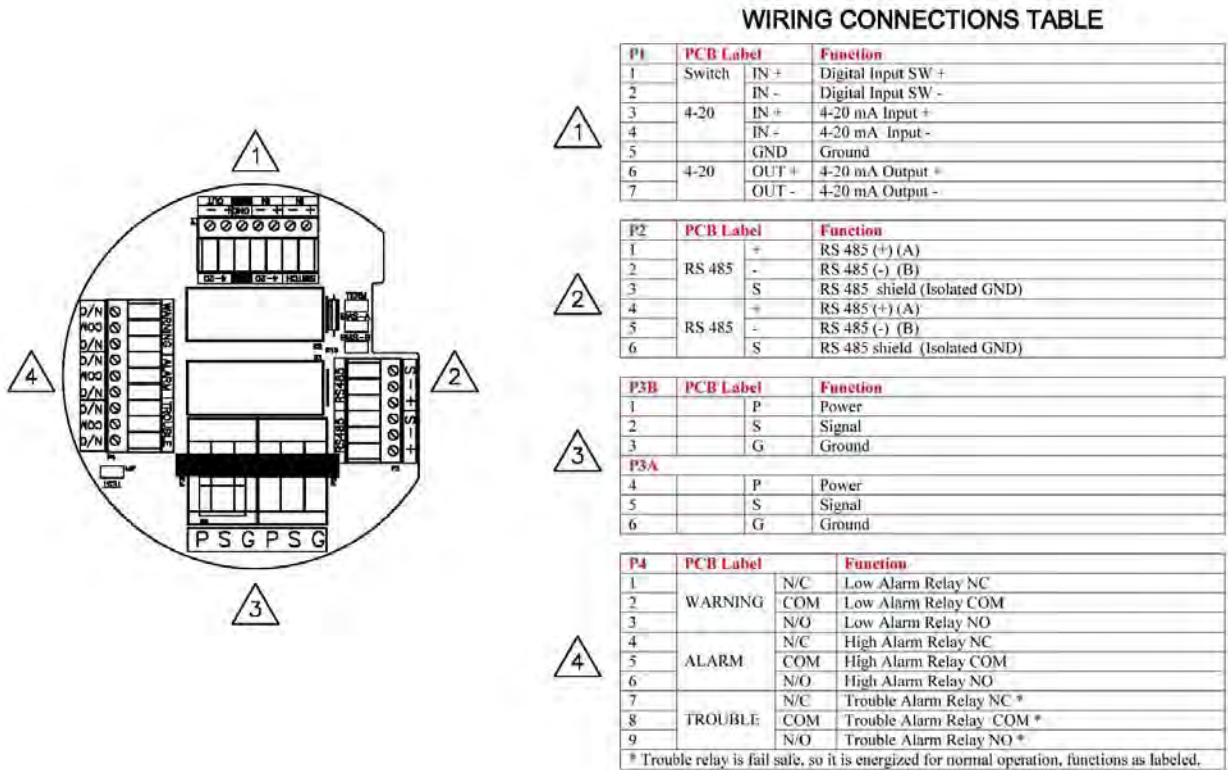


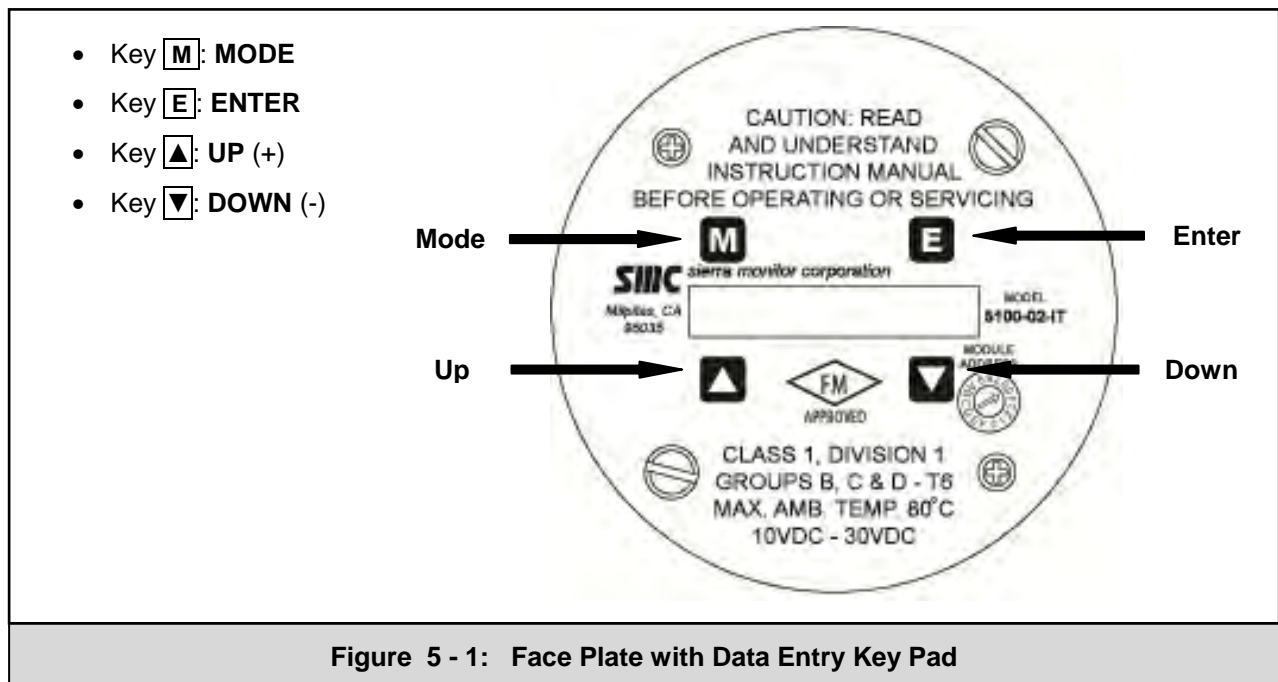
Figure 4 - 7: Termination Drawing

## 5. OPERATION

The Combustible Gas Sensor utilizes a visual menu system operated by means of a magnet. A magnet stick is supplied for this purpose. The menu system is used to configure alarm set-points, calibrate the sensor module, and for maintenance procedures and alarms acknowledge.

### 5.1 DATA ENTRY KEY PAD

The module menu system is operated by means of directing the magnet stick toward each of four independent hall-effect magnetic switches. Each switch functions as if it is a manually activated panel key. The keys are located above and below the faceplate display and are labeled **M**, **E**, **▲**, and **▼** as shown in Figure 5-1.



**5.2 MAIN MENU**

Table 5-1 describes the primary human-machine interface operation.

Key	Function	Display	Description	Reference
M E	Mode		Switch [M]	
▲ ▼				
M E	Enter		Switch [E]	
▲ ▼				
M E	Up		Switch [▲] Previous Menu	
▲ ▼				
M E	Down		Switch [▼] Next Menu	
▲ ▼				
		5100-02	First screen at power up-model	
	1.Xxa	VX.Xxx	Second screen at power up-version	
		Warm.XXX	Third screen at start up-warm up	
		0%LEL	Normal condition - default display	
M E	Mode	ALMRSET:	Mode Function -Alarms Acknowledge	
▲ ▼				
		SSSSSSSS	Banner: Use <M> switch for different menu items. Select <E> to enter menu item.	
		0%LEL	Default Display	
M E	Mode	ALMRSET:	Mode Function - Alarms Reset	
▲ ▼				
M E	Mode	CALIB:	Mode Function - Calibrate	Table 6-1
▲ ▼				
M E	Mode	SETUP:	Mode Function - Module Set-up	Table 5-3
▲ ▼				
M E	Mode	MAINT:	Mode Function - Maintenance	Table 5-4
▲ ▼				
M E	Mode	EXIT-?	Exit Mode	
▲ ▼				
M E	Enter	0%LEL	Apply Selected Mode (Exit)	
▲ ▼				
		0%LEL	Default Display	

**Table 5 - 1: Master Menu**

Table 5-2 describes the operational display values of the human-machine interface system.

Display	Description
STARTING	Warm-up at start-up
###%LEL	Concentration
L ###%LEL	Low Alarm (Warning)
H ###%LEL	High Alarm (Alarm)
HIGH	>100% Full Scale
NO SENSR	Sensor Failure
C ###%LEL	Calibration Mode
ACK	Acknowledged Function

**Table 5 - 2: Operation Display Values**

**ID THE DISPLAY SHOWS "START" INSTEAD OF "STARTING, THE MODULE MUST BE CALIBRATED BEFORE USING IT.**

### 5.3 SET-UP

The sensor module set-points menu is used to initially set-up the alarm set points, relay actions, gas type and range, 4-20 mA action and RS-485/Sentry address and baud rates (See Menu Key in Appendix J). When in the SETUP screen use the [▲] or [▼] keys to select submenu and use [E] to enter.

- **Alarms:** Use the [▲] or [▼] keys to select Low Alarm (Warning) or High Alarm (Alarm) menu. Key [▲] will adjust the setpoint upwards and Key [▼] will adjust the value downwards. Once it reaches the desired setpoint, Key [E] will accept it and ACK will appear. Set-points can be configured using this menu to values between 0 and 60.
- **Relays:** Use the [▲] or [▼] keys to select Low Alarm (Warning) or High Alarm (Alarm) relay menu and press [E]. Use the [▲] or [▼] keys to select the correct alarm relay action for the application, Latch, Sentry or Non-Latch. Selecting "Sentry" enables the Sentry controller to make all alarm action decisions. \* indicates the current selection.
- **Gas Factor:** A calibration standard of Methane may be used in conjunction with scaling factors to cause alarm function in %LEL scale of another gas. See Appendix I for a list of the scaling factors. Note that if the 5100-02-IT is interfaced to a Sentry controller that the gas factor can be set in the Sentry or the Gas Sensor Module but NOT IN BOTH. It is recommended that the gas factor be adjusted in the Gas Sensor Module so that the display values on both the Gas Sensor Module and the Sentry are matched. Note that gas factors are not applicable during calibration.
- **4-20mA:** Use the [▲] or [▼] keys to select Calib, or CalibOut TblOut menu and press [E]. The "Calib" section of the menu allows the user to calibrate the 4 mA and 20 mA outputs. To calibrate the 4 mA and 20 mA outputs it is necessary to have an amp meter connected to the 5100-02-IT and upon selecting the 4 mA output calibration then the [▲] or [▼] keys can be used to adjust the 4 mA reading on the amp meter until it reads 4 mA. Similar steps can then be performed for the 20 mA output. The CalibOut section allows the user to select the 4-20 mA output action desired during calibration. \* indicates the current selected value. Available selections include:
  - **Track** – the 4-20mA value tracks the calibration gas exposed to the gas sensor module
  - **C2.5mA** – the 4-20mA value is held at 2.5mA during calibration
  - **C4.00mA** – the 4-20mA value is held at 4.0mA during calibration.

The Tbl Out menu enables the user to select the mA output value for the Trouble Alarm. Select "T1.5mA" to choose the 1.5mA default valve. Or select "User mA" and use the [▲] or [▼] keys to select any valve between 0.5mA and 3.7mA.

- **RS-485** - Use the [▲] or [▼] keys to select Address or Baud rate menu and press [E]. Note that the 5100-02-IT has a rotary switch on the faceplate and it is used to select addresses 1-15. When connected to Sentry the user can select 1-8 and using Modbus RS-485 the user can select addresses 1-15. For Modbus addresses above 15, set the rotary switch to 0 and then use the "Address" menu to select any address between 16 and 254. The Baud rate menu allows the user to select a baud rate of 38400, 19200, 9600, 4800 or 2400. \* indicates current selection.

RS485 default parameters are: 38,400 baud, 8 bits, 1 stop bit, no parity

Key	Function	Display	Description	Reference
		--0%LEL-	Default Display	
M ▲▼	Mode	ALMRSET:	Mode Function - Alarm Reset	
M ▲▼	Mode	CALIB:--	Mode Function - Calibrate	
M ▲▼	Mode	SETUP:---	Mode Function - Set Point Adjustments	
M ▲▼	Enter	Alarms	S.P. Function - Alarm Adjust	* A Below
M ▲▼	Down	Relays	S.P. Function - Relays Adjust	* B Below
M ▲▼	Down	Gas	S.P. Function - Gas Type/Range Adjust	* C Page 22
M ▲▼	Down	4-20mA	S.P. Function - 4-20 mA Adjust	* D Page 22
M ▲▼	Down	RS-485	S.P. Function - RS-485/Sentry Output Adjust	* E Page 22
<b>High Alarm Set Point Adjustment Example</b>				
M ▲▼	Enter	H.Alarm	S.P. Function - High Alarm Adjust	*A
M ▲▼	Enter	HASP:60-	Alarm Set Point: current = 60	
			Use ▲ or ▼ keys to adjust to new set point	
M ▲▼	Down (x5)	HASP:55-	Alarm Set Point: new = 55	
M ▲▼	Enter	ACK	Momentary Acknowledge of new Set Point	
		H.Alarm	S.P. Function - Alarm Adjust	
<b>Relays Set Point Adjustment Example</b>				
M ▲▼	Enter	H. Relay	S.P. Function - Alarm Relay Adjust	*B
M ▲▼	Down	L.Relay	S.P. Function - Warning Relay Adjust	
M ▲▼	Enter	Latch	Use ▲ or ▼ keys to adjust to new relay action (Latch, Sentry, NonLrtc) * indicates current	
M ▲▼	Down	Sentry	NOTE: Sentry indicates that Sentry controls relay action and not the IT Sensor Module	
M ▲▼	Down	*Sentry	Alarm Relay set to Sentry	
<b>Table 5 - 3 A: Set-Up Configuration</b>				

Gas Factor Example					
M	E	Enter	GasFactr	S.P. Function - Gas Factor Adjust	*C
▲	▼				
M	E	Enter	Factr100	Select [E] to select or ▲ or ▼ to adjust factor number and press [E]	
▲	▼				
M	E	Enter	ACK	Acknowledgement of new Gas Factor Value	
▲	▼				
4-20 mA Adjustment Example					
M	E	Enter	Calib	S.P. Function - Calib Adjust	*D
▲	▼				
M	E	Enter	Out: 4mA	Use ▲ or ▼ keys to select 4 mA or 20mA	
▲	▼				
M	E	Enter	4mA	Selects 4 mA	
▲	▼				
M	E	Enter	ACK	Momentary Acknowledge of new Set Point	
▲	▼				
M	E	Mode	Calib	S.P. Function - Calib Adjust	
▲	▼				
M	E	Down	CalibOut	S.P. Function - Output during Calibration Adjust	
▲	▼				
M	E	Enter	Track	Use ▲ or ▼ keys to select Track, C2.5mA, C4.00mA	
▲	▼				
				Track = Output during calibration tracks the calibration gas, C2.5mA = Output during calibration is 2.5mA, C4.00mA = Output during calibration is 4.0mA	
M	E	Enter	*Track	* = Current selection	
▲	▼				
M	E	Mode	Calib	S.P. Function - Calib Adjust	
▲	▼				
M	E	Down	Tbl Out	S.P. Function - output during Trouble Alarm	
▲	▼				
M	E	Enter	*T1.50mA	Current Valve 1.5mA for Trouble	
▲	▼				
M	E	Down	User mA	S.P. Function - User Selectable mA Valve	
▲	▼				
M	E	Enter	*T1.50mA	Use ▲ or ▼ keys to select mA Valve between 0.5 and 3.7mA	
▲	▼				
M	E	Enter	*T1.50mA	Select 1.50mA for volume during trouble	
▲	▼				
RS-485 Adjustment Example					
M	E	Enter	Address	S.P. Function - RS-485 Address Adjust	*E
▲	▼				
M	E	Enter	Addr:016	Use ▲ or ▼ keys to enter new address	
▲	▼				
M	E	Enter	ACK	New address selected	
▲	▼				
M	E	Enter	Address	S.P. Function - RS-485 Address Adjust	
▲	▼				
M	E	Down	Baud	S.P. Function - RS-485 Baud Rate Adjust	
▲	▼				
M	E	Enter	*38400	Press [E] to select or [▲] or [▼] to select another	
▲	▼				

**Table 5 - 3 B: Set-Up Configuration**



**5.4 MAINTENANCE FUNCTIONS**

The maintenance menu allows the operator to verify module firmware version and configuration code. The maintenance menu operation is described in Table 5-4.

Key	Function	Display	Description	Reference
		0%LEL	Default Display	
M ▲▼	E Mode	ALMRSET:	Mode Function - Alarm Reset	
M ▲▼	E Mode	CALIB:	Mode Function - Calibration	
M ▲▼	E Mode	SETUP:	Mode Function - Set Point Adjustments	
M ▲▼	E Mode	MAINT:	Mode Function - Maintenance	
M ▲▼	E Enter	V2.00aA	Module Version	

**Table 5 - 4: Maintenance Menu**

**6. CALIBRATION**

**6.1 CALIBRATION FREQUENCY**

The 5100-02-IT has been calibrated in the factory prior to shipment. It is recommended that the user check calibration before placing in service. The Combustible sensor module must be calibrated every 6 months. Periodic functional tests are advisable for critical applications and hostile environments.

The sensor module microprocessor software includes high level self checking algorithms which provide continuous sensor diagnostic and self adjustment. Users may elect to increase calibration periods based on low drift experience during the first two calibration periods.

**6.2 CALIBRATION PREPARATION**

Calibration of the Combustible Sensor is accomplished by simple menu based steps and application of span gas.

**NOTE**  
*If an error is made during any stage of the calibration process, hold the magnet stick at the key M for 10 seconds. A scrolling display will indicate "Calibration aborted" and the sensor module will exit the calibration activity and return to normal operating mode. The calibration procedure can then be restarted*

Calibration must be performed only when the area is known to be clear of combustible gas. If necessary, use a portable instrument to confirm that there is no background combustible gas.

For compliance with Factory Mutual (FM) Apparatus, the Sierra Monitor Model 1200-26, 1250-01, 1256-01, 1260 -02 are the only FM Approved calibration gas delivery device. Use Model 5358-01 Calibration Adapter or Model 5360-00 Gas Delivery Fitting.

**6.3 CALIBRATION GAS DELIVERY METHODS**

Calibration gas is can be delivered to the sensors via the following delivery devices:

Model 5358-01: Calibration Adapter - use with portable calibrators. See 6-1.

Model 5360-00: Calibration Gas Delivery fitting - permanently installed fitting which allows tubing to be run to a convenient delivery location

**6.4 CALIBRATION PROCEDURE**

Table 6-1 shows the step by step process of the calibration procedure.

The procedures requires that the menu "keys" be activated using the magnet stick. Each key press steps through the process of setting the zero value for clean air and then setting the span value.

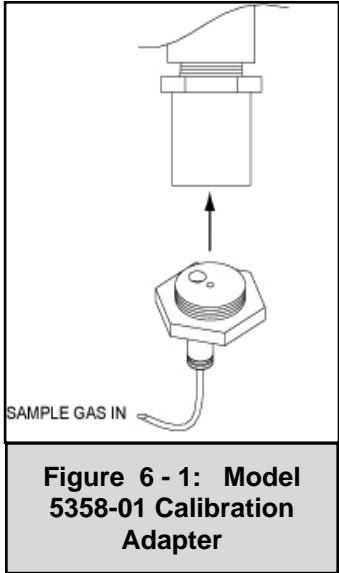
At each of these steps, apply calibration gas of the value corresponding to the setting accepted on the sensor module display.

**6.5 SENSOR EXPOSURE TO GAS**

Calibration gas must be delivered to the sensor using the flow rate and duration listed in below:

Model	Gas	Flow	Period
5100-02-IT	Methane	300 cc/min	Until Stable – 3 minute minimum

**NOTE:**  
*Following calibration, the combustible module counts down for 300 seconds. During this time the module is updating its internal memory and it is very important that its power not be interrupted*



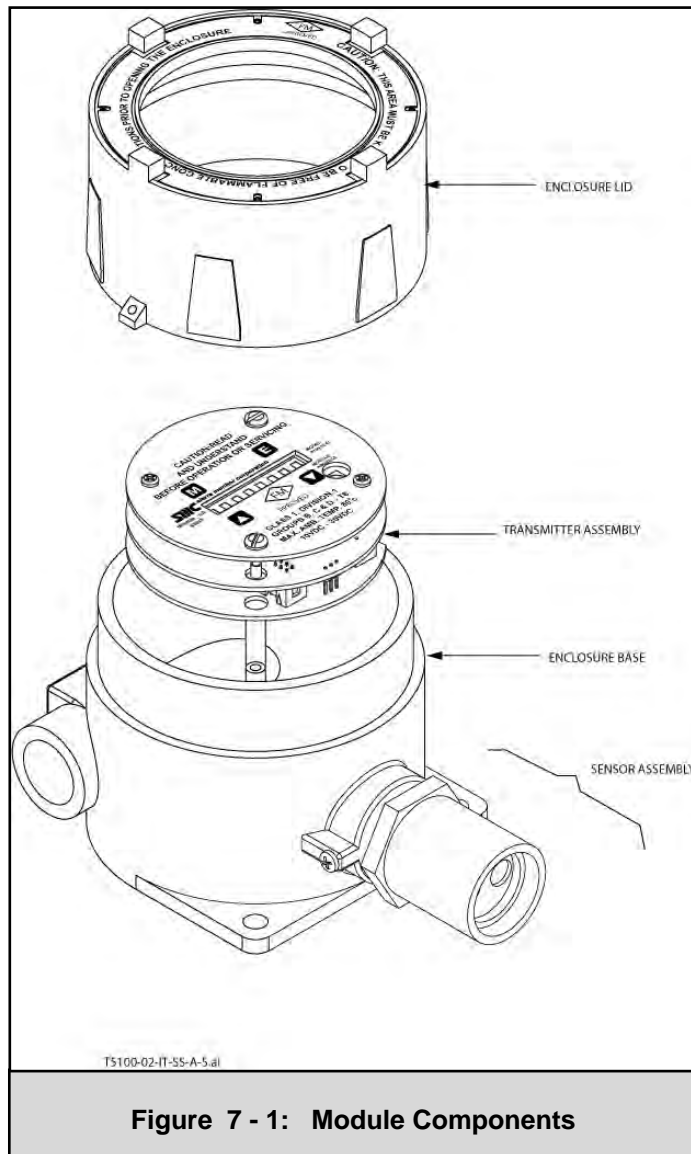
6.6 CALIBRATION SUB-MENU

Key	Function	Display	Description	Reference
		--0%LEL-	Default Display	
M ▲▼	Mode	ALMRSET:	Mode Function - Alarm Reset	
M ▲▼	Mode	CALIB:--	Mode Function - Calibrate	
M ▲▼	Enter	CAL-0%--	Banner: Apply zero gas, enter <E> when done	
			<i>Operation: Confirm area clear of gas, or apply zero air to sensor.</i>	
M ▲▼	Enter	ACK	Zero gas setting acknowledged	
		50%-SPAN	Banner: Select span, enter <E> when done	Sub A
M ▲▼	Enter	CAL-50%	Banner: Apply 50% gas, then enter <E> to calibrate gas sensor	Sub B
		C 0%LEL	<i>Operation: Apply calibration gas.</i>	
		C50%LEL	<i>Operation: As gas is applied the reading will increase - wait 3 minutes</i>	
M ▲▼	Enter	CAL-OK	Calibration Passed - now remove gas	
		WAIT-300	<i>Operation: Five minute time out before sensor is returned to service.</i>	
<b>Sub-Routines</b>				
		50%-SPAN	Banner: Select span, enter <E> when done	Sub A
M ▲▼	Down	25%-SPAN	<i>Operation: Change Span Gas Value to 25%</i>	
M ▲▼	Down	Adj-SPAN	<i>Operation: User adjustable value</i>	
M ▲▼	Enter	50%-SPAN	<i>Operation: Ready for user adjustment</i>	
M ▲▼	Up (x5)	55%-SPAN	<i>Operation: User adjustment to new value 55%</i>	
M ▲▼	Enter	CAL-55%	Banner: Apply 55% gas, then enter <E> to calibrate gas sensor	Sub B
		C 0%LEL	<i>Operation: Apply calibration gas.</i>	
M ▲▼	Enter	CAL-FAIL	<i>Operation: No calibration gas applied, or sensor did not respond correctly.</i>	
		WAIT-300	<i>Operation: Five minute time out before sensor is returned to service.</i>	
M ▲▼	Mode	(Any)	<i>Operation: Hold magnet over Mode Switch for ten seconds to abort calibration</i>	Sub C
			Banner: Calibration Aborted	
		--0%LEL-	Default Display	

**Table 6 - 1: Calibration**

## 7. SERVICE

### 7.1 MODULE SUB ASSEMBLY



**Figure 7 - 1: Module Components**

**NOTE**

*Area must be determined to be non-hazardous before opening enclosure.*

### 7.2 ENCLOSURE REPLACEMENT

The enclosure should be replaced if the cover threads or conduit threads have been damaged, or if the enclosure has been damaged sufficiently that it no longer meets the required NEMA classification.

To replace the enclosure follow the transmitter and sensor assembly removal instructions, remove the damaged enclosure from its conduit, install a new enclosure and continue the transmitter and sensor assembly replacement instructions.

### 7.3 TRANSMITTER REPLACEMENT

The transmitter assembly should be replaced when it is determined that it is unreliable, noisy or cannot be calibrated. This situation may occur due to age, corrosion or failed components.

To replace the transmitter assembly:

- a. Confirm that system power has been removed.
- b. Remove the cover of the main enclosure.
- c. Unscrew the two thumb screws in the top of the cover plate, lift the assembly and rotate 90° to relieve the wiring service loop.
- d. Unplug the sensor connector from the transmitter assembly.
- e. Plug connector into new transmitter (be sure to match numbers between connector and socket).
- f. Restore power and allow a minimum of 2 hours for stabilization before re-calibration.

### 7.4 SENSOR REPLACEMENT

The gas sensor needs replacement when:

- ◆ The "CAL-FAIL" message appears after calibration.
- ◆ The sensor output signal is noisy, causing erroneous gas level readings.
- ◆ The "Sensor Failure" message displays.

To replace the sensor assembly:

- a. Confirm that system power has been removed.
- b. Remove the gas sensor module enclosure cover.
- c. Unscrew the two thumb screws in the top of the faceplate, lift the transmitter assembly and rotate 90° to relieve the wiring service loop.
- d. Unplug the sensor connector from the transmitter.
- e. Unscrew the old sensor assembly from the enclosure conduit hub. Remove the sensor assembly with its harness.
- f. Install new sensor assembly into conduit hub.
- g. Allow the new sensor to stabilize for a minimum of 2 hours and then calibrate using the procedure in Section 6.

### 7.5 INSTALLATION INSPECTION

Prior to system start-up or trouble shooting the entire system should be visually inspected. The following are guidelines for that inspection:

#### 7.5.1.1 CONTROLLER INSTALLATION

- Controller installed in conformance to instruction manual recommendations.
- AC power is correctly grounded.
- Hot AC and relay connections have safety covers installed.

#### 7.5.1.2 SENSOR MODULE INSTALLATION

- Module installation in conformance with this manual.
- Modules accessible for calibration.
- Wiring terminations clean and correct.

#### 7.5.1.3 MOISTURE TRAPS AND RAINSHIELDS

- Conduit seals and drains installed to avoid moisture build up in electronics enclosure. Water accumulation in sensor module enclosures is a major cause of damage and system failures - take precautions to seal electrical conduits and provide moisture traps and drains to avoid water damage
- Rain-shields installed where applicable.

#### 7.5.1.4 STANDARD VOLTAGES

- Regulated DC Voltage to be applied to the sensor module must be between 10 VDC and 30 VDC.

### 7.5.2 INSPECTION AND TROUBLESHOOTING GUIDE

The inspection and troubleshooting guide can be used to step through the system start-up and to determine the corrective action if a fault occurs.

**7.5.3 IF MODULE DOES NOT RESPOND TO GAS**

1. Repeat calibration procedure.
2. Remove the gas and wait for the timer to completely count down.
3. Apply 50%LEL and verify that the sensor sees 50% LEL gas after calibration.
4. If the sensor still does not see gas, power cycle the unit and repeat calibration.

**7.5.4 IF THE MODULE DISPLAYS “STARTING” FOR MORE THAN 1 HOUR**

1. Make sure the sensor is placed in an ambient room temperature environment.
2. Power cycle the sensor.
3. Ensure that the sensor is not exposed to methane during warm-up.

**7.5.4.1 IF THE MODULE DOES NOT DISPLAY THE CORRECT %LEL**

1. Power cycle the unit.
2. Recalibrate the sensor.

**7.5.4.2 IF THE DISPLAY SHOWS ‘F’ – SENSOR FAILURE OR SENSOR MISSING**

1. Power down the unit.
2. Open the enclosure and unplug the sensor assembly from the transmitter board.
3. Plug the sensor back into the transmitter board carefully and ensure a secure fit.
4. Check all other connections.
5. Power up the unit.

**7.5.4.3 IF THE MODULE SHOWS “\*\*\*CALIBRATION REQUIRED\*\*\*”**

1. Calibrate the module.

**7.5.4.4 IF THE DISPLAY SHOWS ‘H’ (OR L) THEN THE LOCAL HIGH OR LOW ALARM IS ACTIVE****7.5.4.5 IF THE DISPLAY SHOWS “M” – NOT CALIBRATED**

1. Calibrate the module.

**7.5.4.6 IF THE DISPLAY SHOWS “C” – CALIBRATION MODE**

1. Complete calibration and exit to operating mode.

**7.5.4.7 IF THE DISPLAY SHOWS “S” – SENTRY CONNECTION**

1. Check connections with Sentry Controller

**7.5.4.8 IF THE DISPLAY SHOWS “SENSOR FAIL”**

1. The sensor assembly is defective, contact technical support

**7.5.5 DIAGNOSTIC LEDS**

LED 1 = 1 Hz Heartbeat normal, 2 Hz Panic Error

2 = Computation process

3 = 1 Hz Heartbeat normal

4 = HART or Sentry comms activity

If the display shows “▼” Down Arrow: Sensor signal too low - Recalibrate

**8. APPENDICES**

**8.1 APPENDIX A: SPECIFICATIONS**

**Sensor:**

Type:	Catalytic Bead
Range:	0-100% LEL Combustible
Repeatability:	+/-1% LEL
Response time:	< 12 sec to 60% full scale
Accuracy:	+/- 1% for 0-50% LEL range +/- 2% for 51-100% LEL range
Sensor Life:	Typically >3 years

**Output:**

Display:	Fixed and Scrolling LED
Relays Option:	Trouble (SPDT Form C, 0.25 Amp@ 250VAC) High Alarm, Low Alarm (5 Amp, 250VAC)
Signal Output:	Sentry Digital Bus Analog 4-20 mA 3-wire Non-Isolated 4-wire Isolated Serial RS-485 Modbus RTU HART

**Input:**

Remote Alarm Reset:	Normally open digital input
---------------------	-----------------------------

**Power:**

Power consumption:	3 watts
Input voltage:	24 VDC nominal: 10-30VDC
RFI/EMI Protection:	EN50081-2, EN50082-2

**Operating Range:**

Ambient Temperature Range:	-40° to 176°F (-40° to 80°C)
Relative Humidity:	0-99% (noncondensing)

**Enclosure:**

Material – Aluminum:	Polyester powder-coated, sand-cast, copper-free aluminum
Material – Stainless Steel:	316 SS optional
Dimensions (H x W x D):	(A1 & A2) 6.9 x 5.7 x 3.9 in. (17.5 x 14.5 x 9.9 cm) (S1 & S2) 7.5 x 5.0 x 4.4 in. (19 x 13 x 11 cm)
Weight:	(A1 & A2) 3.4 lb. (1.5 Kg) (S1 & S2) 7.2 lb. (3.3 Kg)
Housing:	NEMA 4X/7
Hazardous Area Approval:	Explosion proof, Class I, Div. 1, Groups B, C, D Class I, Zone 1, Group IIC, IP66, IP65, NEMA 4X II2 GD, Ex d IIC T6 = -40°C to 85°C

**Approvals:**

Factory Mutual (FM) Performance:	FM Standard 6310 Performance Approval for fixed-based Combustible Gas Detectors (ANSI/ISA – 12.13.01)
Hazardous Locations:	FM Standards 3100, 3600, 3615, 3810
UL:	UL Standard 508A
SIL-2 Certified:	Certified by Lloyds Register (IEC 61508)
ABS:	Certificate of Compliance
CQST	

**Modbus:**

Baud: 38400 (Adjustable 2400 to 38400 baud)  
 Parity: None  
 Stop bit: 1  
 Data bits: 8  
 Flow Control: None  
 Memory map: Appendix H

**Warranty:**

Limited warranty: 2 years

Specifications subject to change without notice



**8.2 APPENDIX B: MODEL NUMBERS, PARTS LIST & PARAMETERS**

<u>Sensor Module</u>					
Model	Enclosure	Relay/Connection		Protection	Remote
5100-02-IT	- XX - A1 = AL 3/4" NPT - A2 = AL M20 x 1.5 - S1 = SS 3/4" NPT - S2 = SS M20 x 1.5	- XX - 01 = No Relays - 02 = Relays - 05 = HART Option	- XX - 00 = Standard	- X - 0 = Standard - 2 = Conformal Transmitter	- X - 0 = None - 1 = Remote Sensor

Options

5311-00 Rainshield  
 5311-02 Rainshield with calibration port

Calibration Items

1250-01 Gas Sensor Calibrator Kit  
 1256-01 Regulator Type A Calibrator  
 1260-00 Gas Cylinder – Air (Type A), 105 liters  
 1260-02 Gas Cylinder – Methane 50% LEL, (type A), 105 liters  
 1260-42 Gas Cylinder - Hydrogen, 50% LEL, (Type A), 105 liters  
 5358-01 Calibration Adapter - Direct, Standard  
 5358-50 Calibration/Configuration Magnetic Tool  
 5360-00 Remote Calibration Fitting

Spare Parts

SPL21813 Transmitter for 5100-02-IT  
 5200-02-IT-AL Sensor Assy for 5100-02-IT, AL  
 5200-02-IT-SS Sensor Assy for 5100-02-IT, SS  
 SPL21810 Enclosure, Transmitter, AL  
 SPL21823 Enclosure, Transmitter, SS  
 SPL21825 Termination Board no Relays  
 SPL21829 Termination Board with Relays  
 SPL21876 HART Termination Board

Factory Default Settings

Output = 3-wire 4-20mA source  
 Range = 0-100% LEL  
 Warning = 20% LEL  
 Alarm = 60% LEL  
 Calibration = 50% LEL Methane  
 Modbus = 2-wire Half Duplex at 38,400 BAUD



**8.3 APPENDIX C: LIMITED WARRANTY**

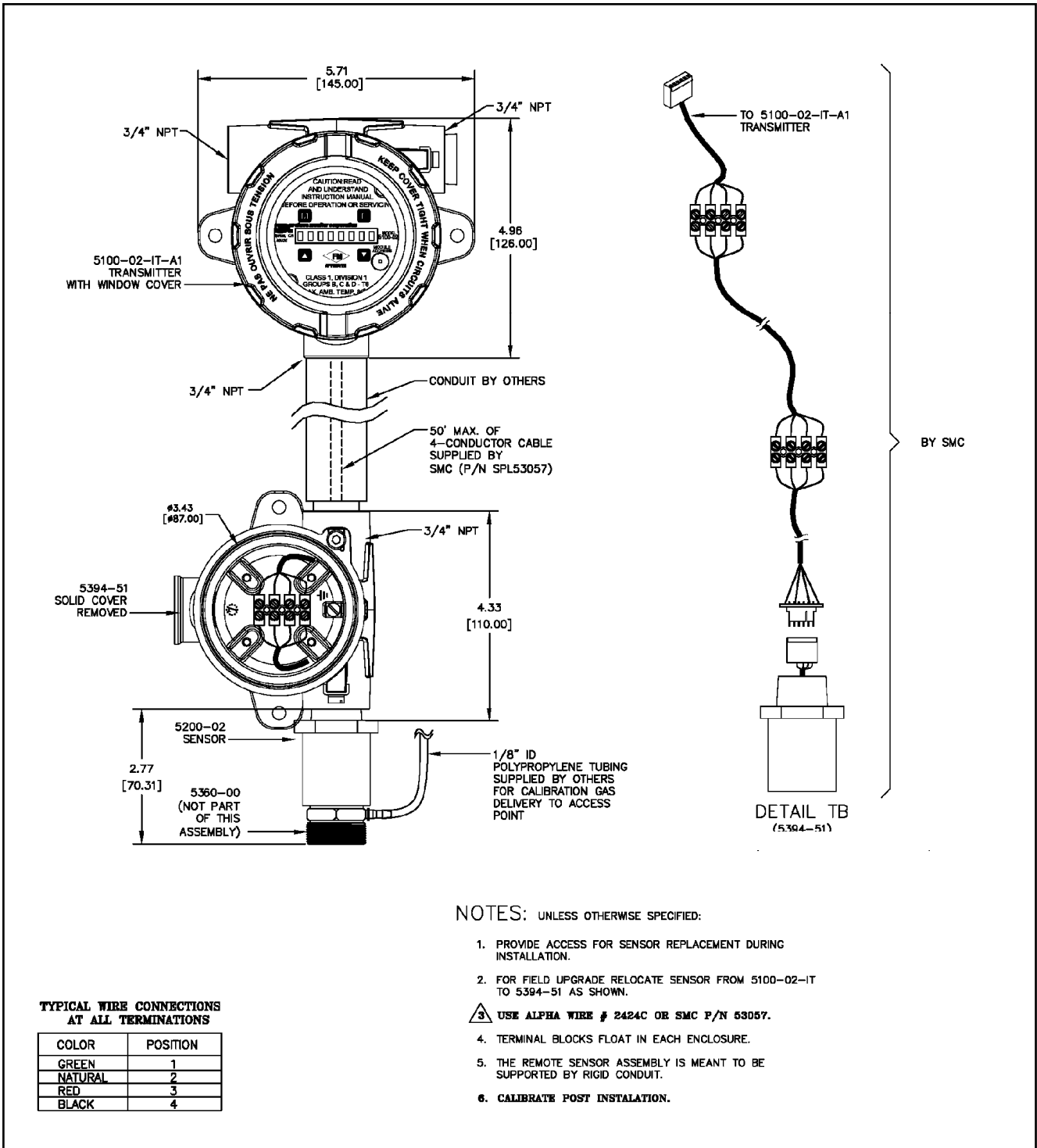
SIERRA MONITOR CORPORATION warrants its products to be free from defects in workmanship or material under normal use and service for two years after date of shipment. SMC will repair or replace without charge any equipment found to be defective during the warranty period. Final determination of the nature and responsibility for defective or damaged equipment will be made by SMC personnel.

All warranties hereunder are contingent upon proper use in the application for which the product was intended and do not cover products which have been modified or repaired without SMC approval or which have been subjected to accident, improper maintenance, installation or application, or on which original identification marks have been removed or altered. This Limited Warranty also will not apply to interconnecting cables or wires, consumables (ie. calibration gases, batteries, sensors), nor to any damage resulting from battery leakage.

In all cases SMC's responsibility and liability under this warranty shall be limited to the cost of the equipment. The purchaser must obtain shipping instructions for the prepaid return of any item under this warranty provision and compliance with such instruction shall be a condition of this warranty.

Except for the express warranty stated above, SMC disclaims all warranties with regard to the products sold hereunder including all implied warranties of merchantability and fitness and the express warranties stated herein are in lieu of all obligations or liabilities on the part of SMC for damages including, but not limited to, consequential damages arising out of/or in connection with the use or performance of the product.

8.4 APPENDIX D: REMOTE SENSOR OPTION



**NOTE:**  
Drawing using Stainless Steel enclosure available from Sierra Monitor.

Setting Up and Testing Model 5100-02-IT with Remote Sensor

1. Connect the remote module (p/n 5394-51) to Model 5100-02-IT.
2. Power up Model 5100-02-IT.
3. Connect the voltmeter from pin 4 to pin 3 of the connector (p/n 59201) (*at the side connected to the sensor*).
4. Verify the voltage from pin 4 to pin 3 is 2 volts. If not, go to maintenance menu:
  - Hit M key 4 times to see Maint: display, then hit E key to enter Maintenance Menu
  - Hit Up Arrow key 5 times
  - Display shows V1 Diag
  - Hit Enter key
  - Hit Up Arrow key to see 2V Output display
5. Adjust the 2V Output (*switch Up Arrow to increase, switch Down Arrow to decrease, and switch E key to accept the change*).
6. Repeat step 5 a few times to get 2 volts at pin 4 and pin 3 of the connector (*2 volts is the bridge voltage of the sensor*).
7. Hit M key a few times to see EXIT display, then hit Enter.
8. Cycle the power.
9. Perform the calibration for Model 5100-02-IT.

8.5 APPENDIX E: HART

### WIRING CONNECTIONS TABLE

P1	PCB Label	Function
1	Switch	IN + Digital Input SW +
2		IN - Digital Input SW -
3	4-20	IN + 4-20 mA Input +
4		IN - 4-20 mA Input -
5		GND Ground
6	4-20	OUT + 4-20 mA Output +
7		OUT - 4-20 mA Output -

P2	PCB Label	Function
1	+	RS 485 (+) (A)
2	RS 485	- RS 485 (-) (B)
3	S	RS 485 shield (Isolated GND)
4	+	RS 485 (+) (A)
5	RS 485	- RS 485 (-) (B)
6	S	RS 485 shield (Isolated GND)

P3B	PCB Label	Function
1	P	Power
2	G	Ground

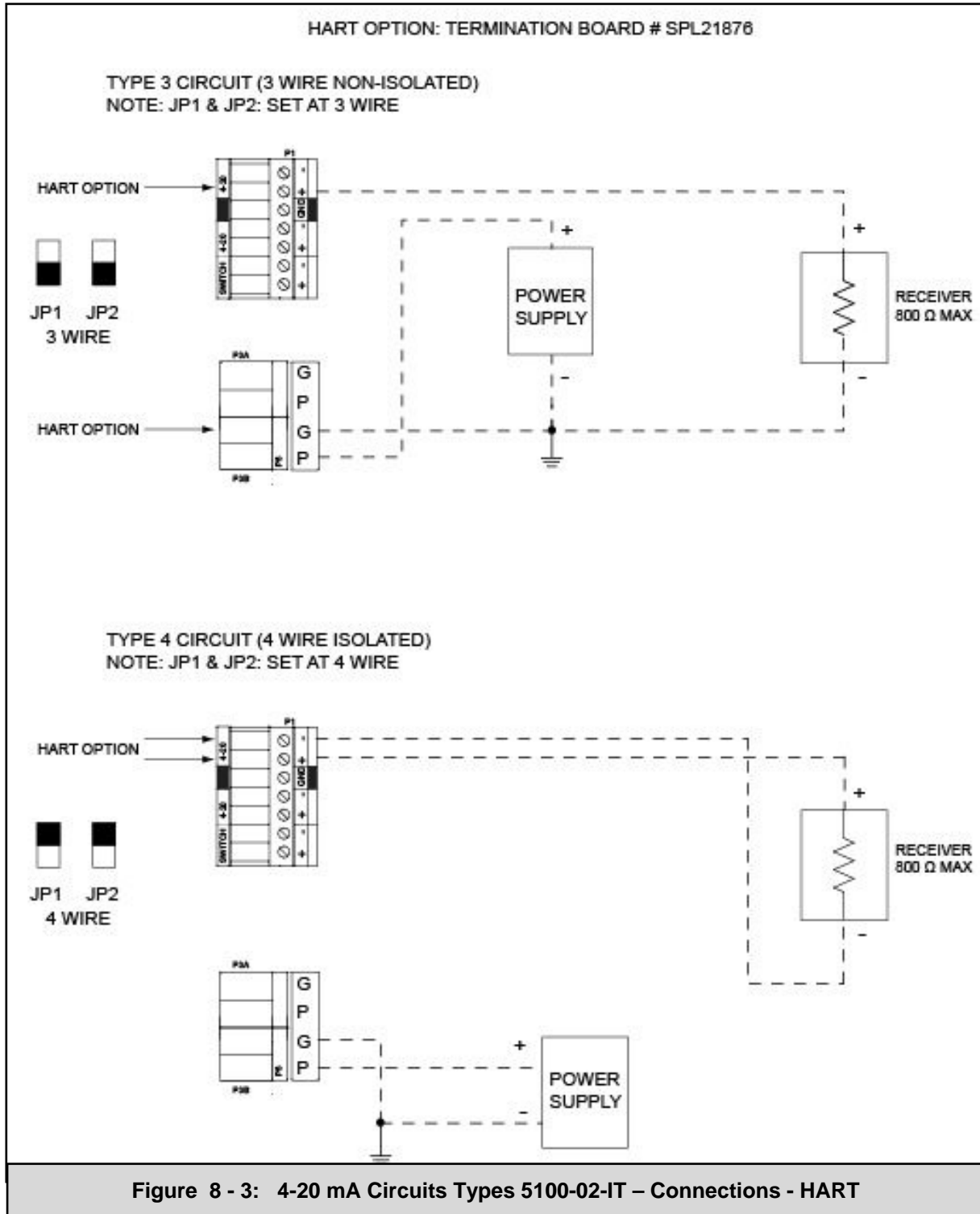
  

P3A	PCB Label	Function
3	P	Power
4	G	Ground

P4	PCB Label	Function
1		N/C Low Alarm Relay NC
2	WARNING	COM Low Alarm Relay COM
3		N/O Low Alarm Relay NO
4		N/C High Alarm Relay NC
5	ALARM	COM High Alarm Relay COM
6		N/O High Alarm Relay NO
7		N/C Trouble Alarm Relay NC *
8	TROUBLE	COM Trouble Alarm Relay COM *
9		N/O Trouble Alarm Relay NO *

\* Trouble relay is fail safe, so it is energized for normal operation, functions as labeled.



**HART PROTOCOL MENU**

HART (Highway Addressable Remote Transducer) Protocol is the global standard for sending and receiving digital information across analog wires between smart devices and control or monitoring system. HART is a bi-directional communication protocol that provides data access between intelligent field instruments and host systems. A host can be any software application from technician's hand-held device or laptop to a plant's process control, asset management, safety or other system using any control platform. The HART protocol used on this gas sensor module has been developed to comply fully with the HART specifications outlined by the HART Communication Foundation (HCF).

If the HART interface board has been provided with the gas sensor module, then HART will operate via the 4-20 mA interface automatically. While no specific handheld device is necessary for HART operation, the gas sensor module does comply with the HART standard so any handheld or PC-based HCF certified tool will work.

The information below provides the operator instructions on connecting HART and the HART Protocol Menu.

**Common Practice Commands**

The following Common Practice commands are implemented.

Command Number	Byte Number	Description
38	N/A	Reset Configuration Changed Flag
48	0	Returns Module Status Module State - In Calibration (0x10), (0x30 = cal passed) (0x50 = cal failed) Module State - Trouble (0x08) Module State - Warming (0x04) Module State - RUN (ALARM) (0x02) Module State - RUN (0x01)
48	1	Returns Alarm Relay Status 0x01 = Alarm Relay ON 0x02 = Warning Relay ON 0x03 = Both Relays ON
48	2	Returns Trouble Status (non-zero value indicates Trouble)
48	3	Returns maximum gas value
48	4	Returns gas value used during calibration
48	5	Returns IT-Series Model Number 0x28 = 5100-IT-28

**Device Specific Commands**

The Device Specific commands are used for accessing the unique features of the 5100-IT Series of gas sensor modules.

A response code of 0 indicates SUCCESS. This applies to all commands. As per HART specification, all command responses will have a response code and status byte, plus any command specific data bytes as indicated in the following tables.

Device Specific Commands Summary

Command Number	Description
130	Key Press
131	Set Alarm Level
132	Set Warning Level
133	Set Alarm Relay Action
134	Set Warning Relay Action
135	Reset Alarms
136	Abort Calibration
137	Set Calibration Gas Level
138	Apply ZERO Gas
139	Apply SPAN Gas
140	RESERVED
141	Force Gas Value
142	Reset Force Gas Value
143	Read MODBUS RTU Register
144	Set Transducer Serial Number
145	Set Calibration Mode output current
146	Set Trouble Mode output current
147	RESERVED
148	RESERVED
149	Set Gas Factor
150	Write MODBUS RTU Register

**Command 130: Key Press**

This command mimics the front plate key inputs.

Request Data Bytes:

Byte	Format	Description
0	Unsigned-8	1=Enter 2=Down 4=Up 8=Menu

Command Specific Response Data Bytes:

Byte	Format	Description
0	Unsigned-8	Returns same value as passed

**Command 131: Set Alarm Level**

Request Data Bytes:

Byte	Format	Description
0	Unsigned-8	Alarm level, range 0 to 60. Default is 60.

Command Specific Response Data Bytes:

Byte	Format	Description
0	Unsigned-8	Returns new Alarm Level.

**Command 132: Set Warning Level**

Request Data Bytes:

Byte	Format	Description
0	Unsigned-8	Warning level, range 0 to 60. Default is 20.

Command Specific Response Data Bytes:

Byte	Format	Description
0	Unsigned-8	Returns new Warning Level.

**Command 133: Set Alarm Relay Action**

Request Data Bytes:

Byte	Format	Description
0	Unsigned-8	0=Latching (default) 2=Non-Latching

Command Specific Response Data Bytes:

Byte	Format	Description
0	Unsigned-8	Returns new Alarm Relay Action value

**Command 134: Set Warning Relay Action**

Request Data Bytes:

Byte	Format	Description
0	Unsigned-8	0=Latching 2=Non-Latching (default)

Command Specific Response Data Bytes:

Byte	Format	Description
0	Unsigned-8	Returns new Warning Relay Action value

**Command 135: Reset Alarms**

This command will reset any alarm relays that have been latched, providing the alarm condition is no longer present on the sensor.

Request Data Bytes: None

Command Specific Response Data Bytes: None

**Command 136: Abort Calibration**

This command aborts the calibration procedure.

Request Data Bytes: None

Command Specific Response Data Bytes: None



**Command 137: Set Calibration Gas Level**

Request Data Bytes:

Byte	Format	Description
0	Unsigned-8	Calibration Gas Level, range 0 to 100

Command Specific Response Data Bytes:

Byte	Format	Description
0	Unsigned-8	Returns new Calibration Gas Level

**Command 138: Apply ZERO Gas**

This command will signal the module to accept the present sensor output to as the ZERO gas condition.

Request Data Bytes: None

Command Specific Response Data Bytes: None

**Command 139: Apply SPAN Gas**

This command will signal the module to accept the present sensor output to as the SPAN gas condition.

Request Data Bytes: None

Command Specific Response Data Bytes: None

**Command 141: Force Gas Value**

Request Data Bytes:

Byte	Format	Description
0	Unsigned-8	Sets the Force Gas Value, range 0 to 100

Command Specific Response Data Bytes:

Byte	Format	Description
0	Unsigned-8	Returns new Force Gas Value

**Command 142: Reset Force Gas Value**

This command will signal the module to set the Force Gas Value to 0.

Request Data Bytes: None

Command Specific Response Data Bytes: None

**Command 143: Read MODBUS RTU Register**

This command allows the reading of sensor module data as defined in the MODBUS RTU register map.

Request Data Bytes:

Byte	Format	Description
0-1	Unsigned-16	Address of Requested Modbus Register 40001 = lowest address 65535 = highest address

Command Specific Response Data Bytes:

Byte	Format	Description
0-1	Unsigned-16	Returns contents of selected Modbus Register

**Command 144: Set Transducer Serial Number**

This command allows user to add a device specific serial number, if required. This is different from the serial number assigned by the Manufacturer.

Request Data Bytes:

Byte	Format	Description
0-2	Unsigned-24	Serial Number

Command Specific Response Data Bytes:

Byte	Format	Description
0-2	Unsigned-16	Returns new Serial Number

**Command 145: Set Calibration Mode output current**

Request Data Bytes:

Byte	Format	Description
0-1	Unsigned-16	Current output required during calibration, in micro-amperes

Command Specific Response Data Bytes:

Byte	Format	Description
0-1	Unsigned-16	Returns new Calibration current value

**Command 146: Set Trouble Mode output current**

Request Data Bytes:

Byte	Format	Description
0-1	Unsigned-16	Current output required to indicate Trouble, in micro-amperes

Command Specific Response Data Bytes:

Byte	Format	Description
0-1	Unsigned-16	Returns new Trouble current value

**Command 149: Set Gas Factor**

Request Data Bytes

Byte	Format	Description
0	Unsigned-8	Sets the Gas Factor value, range 30 to 200

Command Specific Response Data Bytes

Byte	Format	Description
<b>0</b>	Unsigned-8	Returns new Gas Factor value

**Command 150: Write MODBUS RTU Register**

This command allows the writing of sensor module data as defined in the MODBUS RTU register map.

Request Data Bytes

Byte	Format	Description
<b>0-1</b>	Unsigned-16	Address of Designated Modbus Register 40001 = lowest address 65535 = highest address
<b>2-3</b>	Unsigned-16	Data for Designated Modbus Register

Command Specific Response Data Bytes

Byte	Format	Description
<b>0-1</b>	Unsigned-16	Returns MODBUS register value

---

Version 1.20 Updated 30 January 2012

**8.6 APPENDIX F: MODBUS MEMORY MAP**

Register	Description	Read/Write	Comments
40001	Concentration	R	Gas concentration multiplied by Gas Scale (e.g. 209 = 20.9%)
40002	Temperature	R	Temperature in degrees Celcius scaled by a factor of .10
40003	Alarm Relay	R/W	Boolean indicating the Alarm relay status (0 = No Alarm, 1 - (High) Alarm). Clearing bit will reset alarm.
40004	Warning Relay	R/W	Boolean indicating the Warning relay status (0 = No Alarm, 1 - Warning Alarm). Clearing bit will reset alarm.
40005	Warning Setpoint	R/W	Warning Alarm set point, used for activating Low Alarm multiplied by Gas Scale
40006	Alarm Setpoint	R/W	Alarm set point, used for activating High Alarm multiplied by Gas Scale
40007	CCC detail	R	e.g. 0001, 0007, etc
40008	Software Revision U	R	e.g. 201 denotes version 2.01
40009	Software Revision L	R	e.g. version aA is denoted by 0x6141
40010	Modbus Map Revision	R	e.g. version 2 is denoted as v2 = 0x7602
40011	Trouble Bits	R	0 = no trouble
40012	Trouble	R	1 for any trouble, 0 = no trouble
40013	Alarm Immediate	R	Like 40003, but never latched
40014	Warning Immediate	R	Like 40004, but never latched
40015	Serial Number U	R	Serial Number - 24 bits (presently set to Random ID)
40016	Serial Number L	R	
40017	Run time U	R	In seconds
40018	Run time L	R	In seconds
40019	Gas (MAX) value	R	Gas concentration multiplied by Gas Scale
40020	Model	R	Read as 51028 for IR, 51002 for Cat Bead, 51005 for TOXIC H2S etc.
40021	Range	RW	
40022	Units	RW	1 = %LEL, 2 = %VOL
40023	Module Status	R	A bit is defined for each of the following states: (no bit set also means some sort of trouble) Module State - In Calibration (0x40) = cal failed Module State - In Calibration (0x20) = cal passed Module State - In Calibration (0x10) Module State - Trouble (0x08) Module State - Warning (0x04) Module State - RUN (ALARM) (0x02) Module State - RUN (0x01)
40024	Gas Scale	R	Value like 1, 10 or 100
40025	Cal Concentration level	R/W	Gas concentration value used during calibration, multiplied by Gas Scale
40026	Calibration due, in days	R	Gets reset to 365 / 180 if cal successful, Less then 0 = calibration due
40027	Calibration Count	R	Counter increments if cal successful (0 = not calibrated)
40028	Display Gas Output	R	Gas value seen on display (i.e. useful during calibration)
40029	Gas (MIN) value	R	Minimum gas value multiplied by Gas Scale
40030	Alarm Time U	R	In seconds
40031	Alarm Time L	R	
40032	Warning Time U	R	In seconds
40033	Warning Time L	R	
40034	Trouble Time U	R	In seconds
40035	Trouble Time L	R	
40036	Max Gas Time U	R	In seconds
40037	Max Gas Time L	R	
40038	Min Gas Time U	R	In seconds
40039	Min Gas Time L	R	
40040	Rotary Switch	R	Module address (If value < 16, the value reflects position of rotary switch)
40041	Restart Count	R	Restart count
40042	Alarm Relay Action Setup	RW	Alarm Relay Action Setup - Latch/Sentry/Non-latch
40043	Warning Relay Action Setup	RW	Warning Relay Action Setup - Latch/Sentry/Non-latch
40044	4-20mA CalibOut Value	R	
40045	4-20mA TroubleOut Value	R	
40046	Gas Factor	RW	Applies only to -02
40047	Force Value	RW	
40048	Module Number	RW	
40049	Command Register	RW	0 indicates command failed, 1 = passed, supported commands: Lock keys = 101 Unlock keys = 102 Abort calibration = 103 Apply zero gas = 104 Apply span gas = 105 Ack alarms = 106 Reset sensor = 107 Clear mem = 108 Speed up startup = 109 Clear eeprom = 110 Force address disp= 111 Clear address disp= 112
40050	Last command executed	R	Displays last executed command from register 40049

**8.7 APPENDIX G: COMBUSTIBLE GAS SCALING FACTORS**

For combustible gas monitoring, a calibration standard of Methane may be used in conjunction with scaling factors to cause Sentry concentration display and alarm function in %LEL scale of another gas as follows:

GAS	METHANE FACTOR	GAS	METHANE FACTOR
Acetaldehyde	60	Diethyl Ether	46
Acetic Acid	54	Dimethoxyethane	42
Acetic Anhydride	46	Dimethyl Ether	63
Acetone	52	Dimethylformamide	46
Acetylene	57	Ethyl Formate	44
Alkyl Alcohol	51	Ethylmercaptan	56
Ammonia	126	n-Heptane	39
n-Amyl Alcohol	33	n-Hexane	37
Aniline	39	Hydrazine	45
Benzene	41	Hydrogencyanide	48
Biphenyl	25	Hydrogen	77
1,3-Butadiene	56	Hydrogen Sulfide	41
n-Butane	58	Methane	100
iso-Butane	52	Methyl Actetate	50
Butene-1	45	Methyl Alcohol	86
cis-Butene-2	48	Methylamine	77
trans-Butene-2	51	Methyl Bromide	90
n-Butyl Alcohol	34	Methyl Chloride	102
iso-Butyl Alcohol	53	Methylcyclohexane	44
tert-Butyl-Alcohol	74	Methylenedichloride	93
n-Butyl Benzene	31	Methylethylether	44
iso-Butyl Benzene	32	Methylethylketone	41
n-Butyric Acid	38	Methyl Formate	67
Carbon Disulfide	18	Methylmercaptan	61
Carbon Monoxide	75	Methylpropionate	51
Carbon Oxysulphide	93	Methyl n-propylketone	40
Chlorobenzene	34	Napthalene	34
Cyanogen	89	Nitromethane	34
Cyclohexane	41	n-Nonane	31
Cyclopropane	62	n-Octane	37
n-Decane	33	n-Pentane	46
Diethylamine	49	i-Pentane	46
Dimethylamine	58	Propane	55
2,3-Dimethylpentane	40	n-Propyl Alcohol	47
2,3-Dimethylpropane	40	n-Propylamine	48
Dimethylsulphide	43	n-Propylchloride	50
1,4-Dioxane	45	Propylene	52
Epichlorohydrin	45	Propyleneoxide	46
Ethane	68	iso-Propylether	44
Ethyl Acetate	51	Propyne	42
Ethyl Alcohol	73	Toluene	40
Ethylamine	53	Triethylamine	40
Ethyl Benzene	36	Trimethylamine	48
Ethyl Bromide	91	Vinylethylether	42
Ethyl Chloride	57	o-Xylene	36
Ethylcyclopentane	40	m-Xylene	39
Ethylene	71	p-Xylene	39
Ethylenedichloride	66	JP-4 (Jet Fuel)	41
Ethyleneoxide	52		

**NOTES:**

1. Scaling factors are not FMRC approved.
2. Base data source: EEV sensor specification catalog. (EEV claims some data is the result of specific tests, other data is empirically derived).

## 8.8 APPENDIX H: FM APPROVAL



FM Approvals  
1151 Boston-Providence Turnpike  
P.O. Box 9102 Norwood, MA 02062 USA  
T: 781 762 4300 F: 781 762 9375 www.fmglobal.com

## CERTIFICATE OF COMPLIANCE

### HAZARDOUS (CLASSIFIED) LOCATION ELECTRICAL EQUIPMENT

This certificate is issued for the following equipment:

Stationary Gas Detection System. SENTRY system consists of 2, 4 and 8 channel controller Models 5000-02, 5000-04 and 5000-08 for connection to remote digital combustible gas sensor/transmitter Model 5100-02 and 5100-02IT. The system monitors 0-99% LFL of combustible gas-in-air atmospheres. The Model 5100-02 provides a 4-20mA measurement signal, and relay contacts; Trouble, Low and High Alarms. The Model 5100-02IT provides an eight-digit measurement display with magnetically coupled control functions, a 4-20mA measurement signal, and a RS485 measurement signal. The optional Remote Display (model 5394-51) connects to the 5100-02IT via the 4-20mA measurement signal and provides an eight-digit measurement display with magnetically coupled control functions, a 4-20mA measurement signal, and relay contacts; Trouble, Low and High Alarms. The controller is for use in indoor or optional outdoor (NEMA 4X) nonhazardous locations, the combustible gas sensor/transmitter is for use in Class I, Division 1, Groups B, C and D hazardous (classified) indoor locations. The controller is panel mounted and can be operated from 120 Vrms, 220 Vrms, 50/60 Hz or 12 V dc. The controller provides the following standard functions: 2, 4 or 8 channel measurement, displays, keypad and common High/Low Trouble alarm contacts. The following are FM Approved controller options: Model 5380-00 Controller 19 in. rack mounting accessory, Model 5383-00 Controller NEMA 4X enclosure, Model 5392-00 individual 8 channel high and low alarm contacts, and Model 5387-00 Serial RS-232 printer port software. Included in the Approval are: conventional and multiplexed sensor/transmitter installation configurations, normal and global calibration modes, user editable channel tag function, combustible gas calibration delivery system Model 1200-26 with gas cylinder; for methane (Model 1290-02) or hydrogen (Model 1250-01). A combustible gas calibration delivery fitting Model 5360-00, calibration adaptors Models 5358-00 and 5358-01. Operating temperatures are 0° to 50°C (32° to 122°F) for the controller, -40° to 80°C (-40° to 176°F) for the combustible gas sensor/transmitter. Approval covers use of the instrument when the instrument calibration is performed using the gas to be monitored and when the higher of the two alarm set points is preset within 10% LFL of the monitored calibration gas concentration.

Stationary Gas Detection System. SENTRY system consists of 2, 4 and 8 channel controller Models 5000-02, -04 and -08 for connection to remote digital hydrogen sulfide gas sensor/transmitter Model 5100-05. The system monitors 0-100 ppm hydrogen sulfide gas-in-air. The controller is for use in indoor or optional outdoor (NEMA 4X) nonhazardous locations and the hydrogen sulfide gas sensor/transmitter is for use in nonhazardous indoor locations. The controller is panel mounted and can be operated from 120 Vrms, 220 Vrms, 50/60 Hz or 12 V dc. The controller provides the following standard functions: 2, 4 or 8 channel measurement, displays, keypad and common High/Low Trouble alarm contacts. The following are FM Approved controller options: Model 5380-00 Controller 19 in. rack mounting accessory, Model 5383-00 Controller NEMA 4X enclosure, Model 5392-00 Individual 8 channel high and low alarm contacts, and Model 5387-00 Serial RS-232 printer port software. Included in the Approval are: conventional and multiplexed sensor/transmitter installation configurations, normal and global calibration modes, user adjustable full scale function for hydrogen sulfide channels up to 100 ppm, user editable channel tag function, calibration gas fitting Model 5360-00, calibration adaptors Models 5358-00 and 5358-01. Operating temperatures are 0° to 50°C (32° to 122°F) for the controller and -10° to 50°C (14° to 122°F) for the hydrogen sulfide sensor/transmitter.

FM Approved for:

Sierra Monitor Corporation  
1991 Tarob Court Milpitas, CA 95035 USA

FM Approvals GAS 1/06

2V4A4.AX  
Page 1 of 2



This certifies that the equipment described has been found to comply with the following Approval Standards and other documents:

Class 3600	1998
Class 3615	1989
Class 3810	1989
Class 6310	2001
Class 6341(Draft)	1986

Original Project ID: 2V4A4.AX

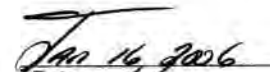
Approval Granted: April 21, 1992

Subsequent Revision Reports / Date Approval Amended


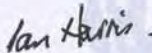
Report Number	Date	Report Number	Date
0Z3A7.AX	December 1, 1995		
3025432	JAN 16, 2006		

FM Approvals LLC

  
Robert L. Martell, Jr.  
Vice President

  
Date

## 8.9 APPENDIX I: SIL-2 APPROVAL CERTIFICATE

	Certificate no: 2020-07-010-05-04-001 Page 1 of 1
 Pellister Gas Detector type 5100-02-IT	
Office: Aberdeen	
Date: 22 <sup>nd</sup> May 2009	
This certificate is issued to Sierra Monitor Corporation of 1991 Tarob Court, Milpitas, CA 95035	
<b>Component Description</b> Pellister Catalytic Gas Detector (including sensor head) instrument	
<b>Component Identification</b> Model 5100-02-IT	
This certificate is issued to the above manufacturer to certify that Lloyd's Register EMEA have examined a Failure Mode and Effect Analysis performed by Technis (Dr David Smith) and assisted by Sierra Monitor Corporation (Franco Giangregorio) and verify the findings are correct in the following respects:	
<ol style="list-style-type: none"><li>1. In respect of the failure mode (<b>Failure to Respond to a predetermined gas concentration by means of a 4-20mA signal</b>), the demonstration (by means of failure mode and effect analysis) of &gt;90% safe failure fraction which makes it suitable for <b>SIL 2</b> application when used in a simplex mode, without redundancy as detailed in Technis report T442.</li><li>2. A probability of failure on demand (based on FMEA) of <math>4.5 \cdot 10^{-4}</math> assuming a proof test interval of 12 months and a repair time of 4 hours as detailed in Technis report T442.</li><li>3. Appropriate control over purchased materials.</li><li>4. Independence of the review and assessment as detailed in Technis report T442 is confirmed.</li><li>5. Components are as listed in Technis report T442.</li><li>6. The detector(s) must be correctly designed into a Safety Instrumented Function per the requirements of the Safety Manual.</li><li>7. The results of the proof tests and any revealed failures need to be correctly recorded and analysed to ensure the integrity requirements are met throughout the lifecycle of the plant/process.</li></ol>	
<b>Applicable Standards</b> IEC 61508 – Functional Safety of Electrical/Electronic/ Programmable Electronic Safety Related Systems	
<b>Design Temperature</b> Temperature rating: -40°C min. to +80°C max (unless stated in applicable certification)	
<b>Maintenance schedule</b> It is recommended that a periodic visual and operation evaluation is carried at least once a year	
<b>Product life</b> As determined by the Maintenance schedule above	
<b>Control of Internal Production Compliance</b> ISO 9001:2008 (Certificate of Registration 74 300 2690 A) issued by TUV Rheinland, North America, Inc valid to 16 <sup>th</sup> Feb 11	
This certificate is issued to the above client to certify that the detector described herein has been subjected to a Failure Modes and Effects Analysis in accordance with the requirements of Lloyds Register and the standards indicated above. This certificate is not valid for equipment, the design or manufacture of which has been varied or modified from the specimen tested. The manufacturer should notify Lloyd's Register of any modification or changes to the equipment in order to obtain a valid Certificate.	
Date of issue: 22 <sup>nd</sup> May, 2009	
Expiry date: 22 <sup>nd</sup> May, 2014	 Ian Harris Surveyor to Lloyd's Register EMEA  A member of the Lloyd's Register Group
Lloyd's Register, its affiliates and subsidiaries and their respective officers, employees or agents are, individually and collectively, referred to in this clause as the 'Lloyd's Register Group'. The Lloyd's Register Group assumes no responsibility and shall not be liable to any person for any loss, damage or expense caused by reliance on the information or advice in this document or howsoever provided, unless that person has signed a contract with the relevant Lloyd's Register Group entity for the provision of this information or advice and in that case any responsibility or liability is exclusively on the terms and conditions set out in that contract.	
Form 1124Local (2005.02)	



**INDEX**

4-20 MA .....	3, 20, 22	MODULE.....	7, 9
ALARMS .....	20, 44	MODULE ADDRESS SWITCH.....	13
ANALOG .....	4	OPTIONS.....	30
CALIBRATION.....	10, 24, 30	POWER REQUIREMENTS .....	5
CALIBRATION FREQUENCY .....	3, 24	RELAYS.....	4, 20
CALIBRATION GAS DELIVERY .....	24	REMOTE ALARM .....	3, 4
CALIBRATION PREPARATION.....	24	REMOTE SENSOR .....	3, 4, 33
CALIBRATION PROCEDURE.....	24	REPLACEMENT .....	26, 27
COMBUSTIBLE GAS SENSOR .....	3	RS-485.....	11, 20, 22
COMBUSTIBLE GASES DETECTED .....	8	SENSOR.....	4, 12, 27
DATA ENTRY KEY PAD .....	18	SENSOR EXPOSURE TO GAS .....	24
ENCLOSURE .....	3, 4, 11, 26	SENTRY .....	3, 11
ENHANCED CONNECTION .....	4	SERVICE .....	26
FM APPROVED.....	3, 48	SET-UP .....	20, 46
GAS FACTOR .....	20	SIL-2 .....	3, 50
GAS SCALING FACTORS .....	43	SPARE PARTS.....	30
GAS TYPE .....	22	SPECIFICATIONS.....	29
HART .....	4, 33, 34, 36, 42	START-UP .....	9
INSTALLATION .....	9, 10, 12, 27	TRANSMITTER .....	4, 7, 9, 12, 27
MAINTENANCE.....	23	TROUBLESHOOT .....	27
MENU KEY .....	44	WARRANTY .....	31
MODBUS.....	3, 4, 20, 42	WIRING.....	5, 7, 9
MODEL NUMBER .....	30		